

Proportional Directional Valves

Series L.8S Preference Program

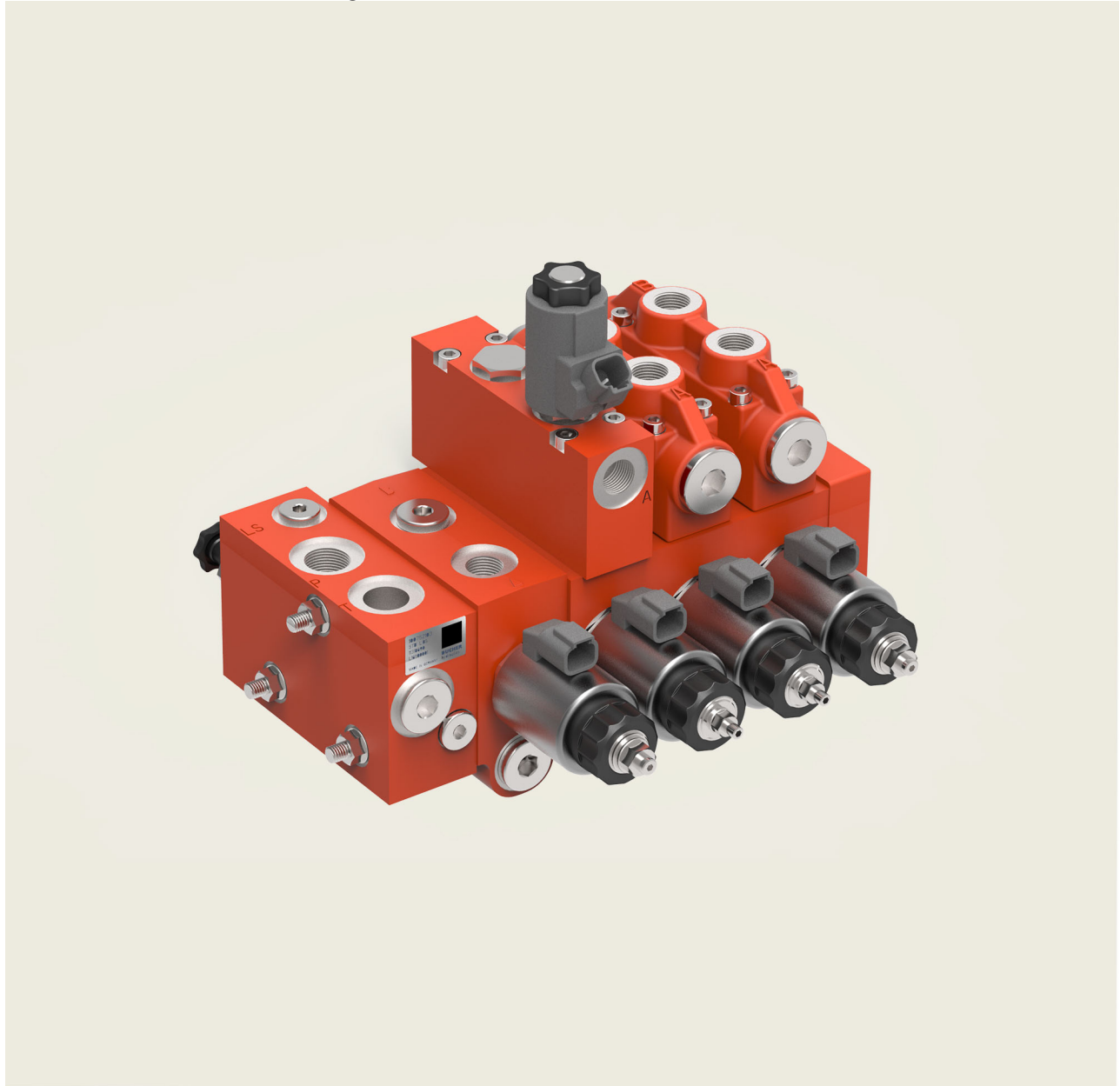

Contents	Page
1	General description 5
1.1	Note on the unique identification of the various sections 6
2	The main components 7
2.1	Inlet and end sections for valve blocks 7
2.2	Inlet and intermediate sections 7
2.3	Directional valves 7
2.4	Auxiliary valves 7
2.5	General technical data 8
3	Inlet sections 9
3.1	Inlet section without function 9
3.2	Inlet section with pressure relief 10
3.3	Inlet section with 2-way compensator 12
3.4	Inlet section with 3-way compensator 13
4	Intermediate sections 17
4.1	Intermediate section with no control function 17
4.2	Intermediate section with 2-way pressure compensator 18
4.3	Intermediate sections with 3-way pressure compensator 19
4.4	Intermediate sections with multi-way pressure compensator 21
5	Directional valves 23
5.1	LD8S- /LC8S-Directional valve 23
6	Auxiliary valves that bolt-on to the top connection face O 31
6.1	Anti-shock/make-up valve (secondary pressure relief) 31
6.2	Check valve (pilot operated non return valve) 33
6.3	Load control valve 35
7	End sections 37
7.1	With no control function 37
7.2	Safety valve for electro-hydraulic steering systems 38
8	Configuration of control blocks 40
8.2	Assembly kit 40
9	Liability 41
10	Note 41

1 General description

The L.8S valve series was developed for mobile applications and it features a robust design and small external dimensions.

The L.8S valve range is a very flexible building-block system - its elements can be selected and assembled into a valve block that provides the necessary functions and precisely meets the needs of the application.

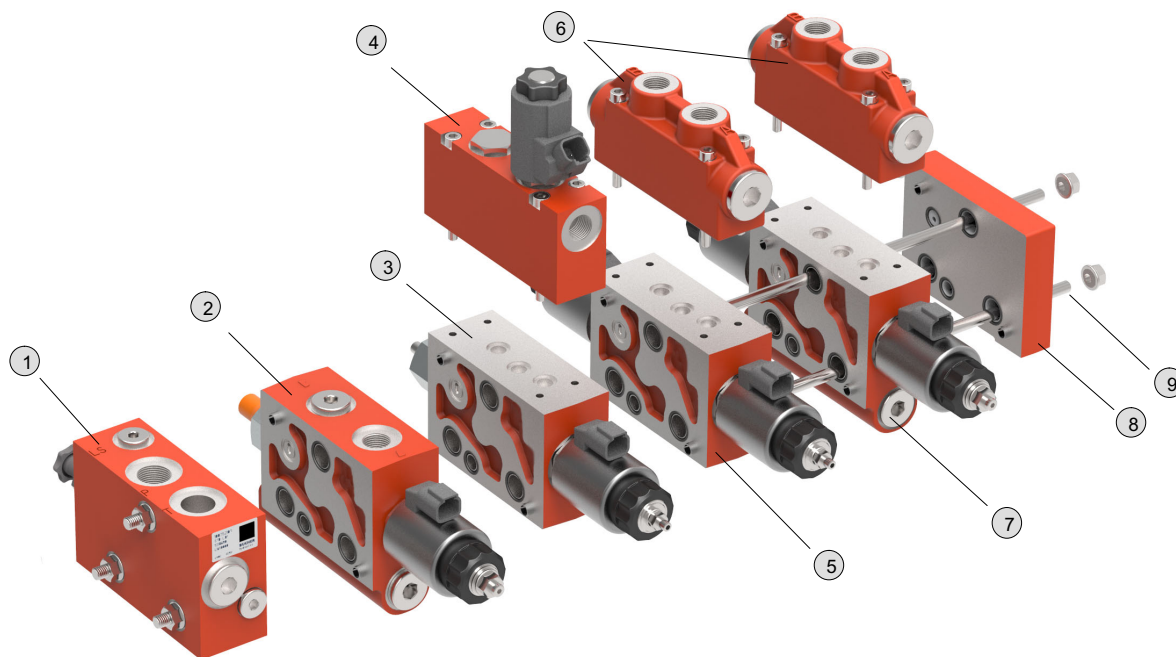

Item	Description
1	Inlet section with 3-way compensator (chapter 3)
2	Directional sections with port threads, with integral individual pressure compensator / solenoid, direct-acting (chapter 5)
3	Directional sections with flange face for auxiliary valve / solenoid, direct-acting (chapter 5)
4	Auxiliary valves that bolt-on to the top flange face O (chapter 6)
5	Directional sections with flange face for auxiliary valve / solenoid, direct-acting (chapter 5)
6	Auxiliary valves that bolt-on to the top flange face O (chapter 6)
7	Directional sections with flange face for auxiliary valve and integral individual pressure compensator / solenoid, direct-acting (chapter 5)
8	End sections (with no control function) (chapter 7)
9	Stud bolts / seal-lock nuts (chapter 8)

The following components are available within the range:

Block termination components

- inlet sections
- end sections

Intermediate sections

- 2-way pressure compensators
- 3-way pressure compensators
- multi-way pressure compensators

Directional valves with auxiliary valves

- load check valves
- anti-shock valves
- individual pressure compensators (2-way)

and many more.

Within the valve block, directional valve sections are connected in parallel to the pressure, tank and control lines.

In a system with a fixed-displacement pump, a typical valve block contains a 3-way compensator, several directional valves and the necessary block termination components. The pump is connected to the valve block by a pressure line.

When all directional valves are in the neutral position, the control line unloads the 3-way compensator to tank. The entire flow supplied to the valve therefore passes - with minimal unloaded pressure drop - through the 3-way compensator to the tank port or the carry-over port.

When one of the directional valves is operated, the load pressure is signaled through the control line to the 3-way compensator. The 3-way compensator keeps the pressure difference between the pressure and control galleries inside the block at a constant level (the control pressure). The flow rate to the actuator is therefore always independent of the load and proportional to the open flow area of the metering orifice in the directional valve that has been operated.

In a system with a pressure-controlled, variable-displacement pump, a typical valve block contains (in addition to the directional valves and block termination components) a 2-way compensator that must be positioned between the pump port and the pressure gallery inside the block.

When all directional valves are in the neutral position, the 2-way compensator closes the inlet to the valve block. When one of the directional valves is operated, the 2-way compensator reduces the inlet pressure to a level sufficient to keep the pressure difference between the pressure and control galleries inside the block at a constant level. This ensures that the flow rate to the actuator is independent of the load and proportional to the open flow area of the metering orifice in the directional valve. The flow rate supplied to the valve block therefore matches the actual demand.

When a valve block is supplied by a variable-displacement pump with a load-sensing control, the pump can be connected directly to the valve block by a pressure line. In addition, the control line is connected to the pump control port. If the control pressure can be adjusted directly at the pump control, it is then possible to set the actuator flow rate to the specified value without any additional measures.

If the pump control pressure is preset, the specified flow rate is achieved by placing a 2-way compensator before the directional valve.

When all directional valves are in the neutral position, the pump is de-stroked. When one of the directional valves is operated then, due to the effect of either the pump control or the 2-way compensator positioned before the directional valve, the necessary control pressure is maintained between the pressure and control galleries inside the block. The flow to the selected actuator is therefore independent of the load and proportional to the open flow area of the metering orifice in the directional valve.

In all of the system configurations described up to this point, when several directional valves are operated then, thanks to the shuttle valves situated in the control lines, the actuator with the highest load will dictate the control pressure and the flow rate to the actuator will be independent of the load and proportional to the open flow area of the metering orifice in the directional valve. Load-independence for the less highly-loaded actuators can be achieved by using individual pressure compensators, which reduce the excessive pressure difference sufficiently to ensure that the required control pressure exists at the corresponding directional valve.

1.1 Note on the unique identification of the various sections

For all adjustable sections (auxiliary-function sections and directional sections), the flow rate specification Q= and pressure specification P= must be stated clearly and within

the limits of the prescribed flow rate and pressure specifications. These can be found in the relevant document section.

1.1.1 Example

Example 1:

LU8SSCS-0M22**00/P=

=> LU8SSCS-0M22*00/P=210

Example 2 with spool stroke limiter:

LD8SE4A2525-S*L-1M18T18*00/P=

=> LD8SE4A2525-S*L-1M18T18*00/P=180QA=18QB=21

The products are assembled in accordance with the specified setting parameters.

2 The main components

2.1 Inlet and end sections for valve blocks

Every L.8S series valve block requires two block termination components in the form of one inlet section and one end section. These two components are used for mounting the block, the block tie bolts pass through them, and they are provided with hydraulic ports.

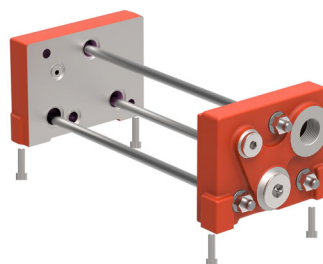

2.2 Inlet and intermediate sections

2.2.1 2-way pressure compensator

The 2-way compensator is a valve that controls a pressure differential. It is situated inside the block, before the pressure gallery. In this valve, the inlet pressure is reduced by the amount needed to ensure that the control pressure between the pressure and control galleries inside the block is kept constant. In some models, the valve closes the inlet to the block if the pressure in the control line reaches the setting of an upstream pressure relief valve.

The 2-way compensator can be supplied as an inlet section or an intermediate section.

2.3 Directional valves

The control options LC or LD (ON/OFF) for L.8S series directional valves enable continuous changes to the flow area of the metering orifice, which in turn determines the flow rate that is supplied to the actuator. This is achieved by arranging that in the first group of valves the spool can stop at any desired point along its total stroke, whereas the spools of LD valves travel from one end of the stroke to the other when they are switched, and do not stop at intermediate positions.

The LD and LC directional valves are electrically operated, direct acting. The solenoids of LD and LC directional valves are fitted with a manual override as standard. Series LD and LC directional valves can be equipped with an optional hand lever for manual-override operation of the valve spool. Operating two valves in parallel is dependent on the pressure demands of the actuator connected to each valve. However, the LD- and LC- directional valves can optionally be ordered with an integral individual pressure compensator.

2.2.2 3-way pressure compensator

The 3-way compensator is a valve that controls a pressure differential. It is situated between the pressure gallery and the tank or carry-over gallery. The valve keeps the pressure difference between the pressure and control galleries inside the block at a constant level and surplus flow passes to the tank or carry-over port. If the pressure in the control line reaches the setting of an upstream pressure relief valve, the 3-way compensator opens the connection to tank, thus limiting the pressure in the pressure gallery inside the block. In one particular model, the function of the 3-way compensator can be customized to suit the requirements of individual applications. The adjustment can be done with a shut-off screw that is accessible from the outside.

2.4 Auxiliary valves

The auxiliary valves fit onto the directional valves and can be flange-mounted on the top (connection face O) or bottom (connection face U) of the valve, which is specially designed for this purpose.

For mounting on connection face O, these alternative auxiliary valves are available:

- anti-shock valve (secondary pressure relief valve with make-up facility)
- load control valve
- load check valve (hydraulically and electrically pilot-operated check valve)
- various special bolt-on plates

Anti-shock valves are used to prevent over-pressure in the actuator lines and/or cavitation with negative loads.

Load control valves provide controlled, load-independent lowering of over-running (pulling) loads. The anti-shock function is integrated and optimal adjustable.

Load check valves hold the actuator, which may be under load, with virtually zero leakage. The actuator is released by applying pressure to the other actuator port.

An individual compensator is used when the flow rate to the actuator must be independent of load, but the inlet compensator cannot perform the necessary pressure-control function. LC- and LD- directional valves are also available with integrated individual pressure compensator.

Additional function blocks are described in detail in the relevant sections.

2.5 General technical data

General characteristics	Unit	Description, value
Recommended mounting attitude	GPM (l/min)	With spool axis horizontal
Nominal flow rate	GPM (l/min)	max. 39.63 (150)
Actuator flow rate	GPM (l/min)	max. 15.85 (60)
Inlet pressure P + D	PSI (bar)	max. 3626 (250) ²⁾
Actuator pressure A + B	PSI (bar)	max. 3626 (250) ²⁾
Intermittent pressure (max. 10 sec/min)	PSI (bar)	max. 4041 (280)
Return line pressure	PSI (bar)	max. 580 (40) ¹⁾
Hydraulic fluid		Recommendation: high-quality fluids with a mineral-oil base, such as HLP oils to DIN 51524 part 2
Seal material		NBR
Fluid temperature	°F (C°)	-13 ... +176 (-25 ... +80)
Ambient temperature	°F (°C)	-13 ... +122 (-25 ... +50)
Viscosity range	ft ² /s (mm ² /s)	1.08 ... 41.04 (10 ... 380)
Minimum fluid cleanliness level		ISO 446, code 20/18/15
Nominal voltage range of switching solenoids	VDC	12V $\underline{\Delta}$ 10.8 ... 14 24V $\underline{\Delta}$ 21.6 ... 28
Servo frequency	Hz	preferably 100
Threaded ports		to DIN 3852 and DIN ISO 228-1
Tie bolts		M8, tensile grade 10.9 (tightening torque 266 lbs (30 Nm))
Corrosion protection		Valve blocks primed colour: black RAL 9005 coating thickness 30 to 50 μm ³⁾
MTTF _D - value		150 years, see datasheet 100-KB-000083

1) 1450 PSI (100 bar) return line pressure for brief periods, with max. inlet pressure 3046 PSI (210 bar). 3046 PSI (210 bar) for P and T in individual cases. For higher pressures, consult Bucher Hydraulics.

2) The stated pressures are the maximum absolute pressure limits for a tank line pressure of 145 PSI (10 bar).
Note: Some components have lower individual pressure ratings.

3 Inlet sections

3.1 Inlet section without function

3.1.1 Description

Inlet sections without function are used to begin the block when no control functions are needed (e.g. LS applications). Ports P, T and LS, and tapped holes for securing the valve block are provided.

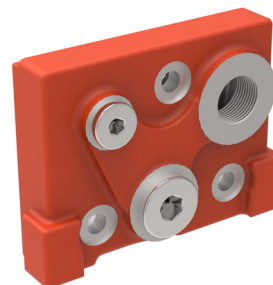

3.1.2 Overview of sections

Symbol	Description	Part number
	LU8SPOG-0U78 <ul style="list-style-type: none"> Without function port threads to ISO 11926: 7/8" -14 UNF-2B 	100026482

3.1.3 Dimensions [in (mm)]

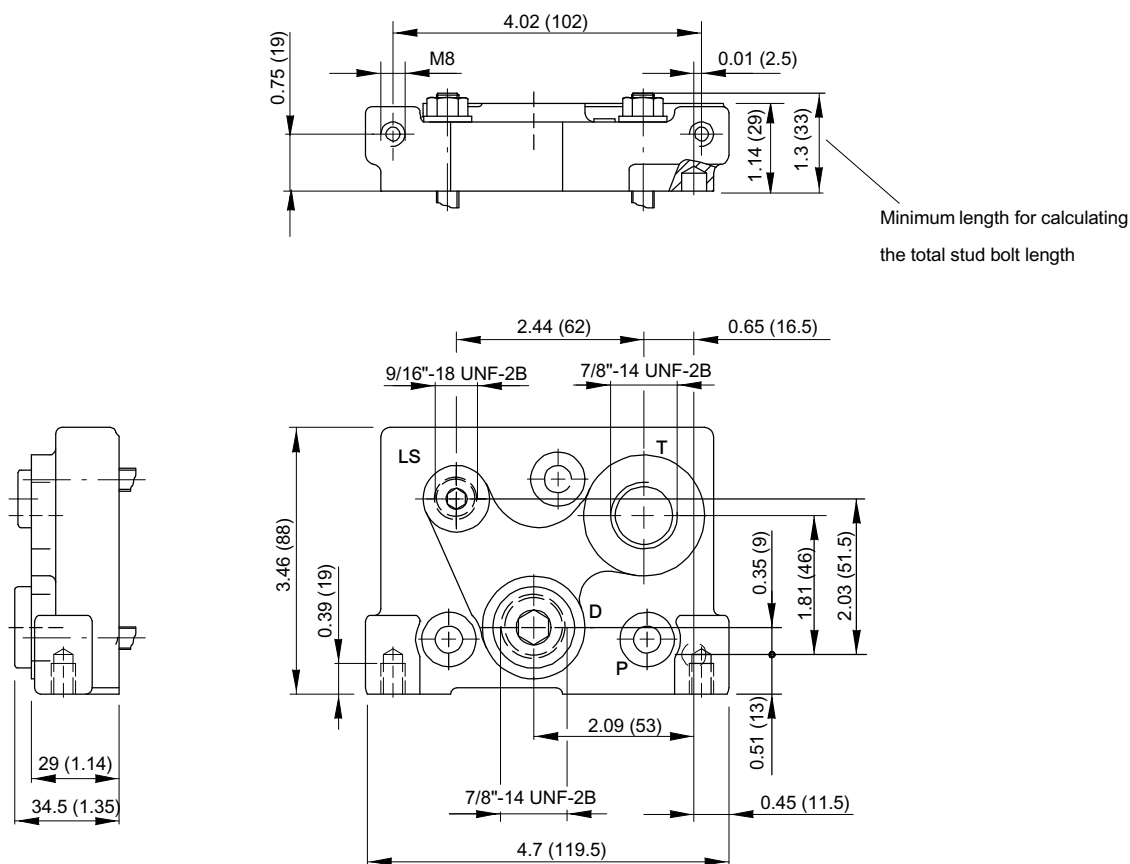

3.2 Inlet section with pressure relief

3.2.1 Description

3.2.1.1 Inlet pressure relief two-stage LU8SPOD

This is used to begin the block, and has an integral two-stage pressure relief function (e.g. safety pressure relief in an LS system). Ports P, T and LS, and tapped holes for securing the valve block are provided.

3.2.1.2 Inlet pressure relief direct acting LU8SPOS

This is used to begin the block, and has an integral direct-acting pressure relief function (e.g. secondary pressure relief in an LS system). The application limits must not be exceeded. By screwing in damping and bypass orifices, many possibilities for combating oscillation problems in LS systems can be created. Ports P, T and LS, and tapped holes for securing the valve block are provided.

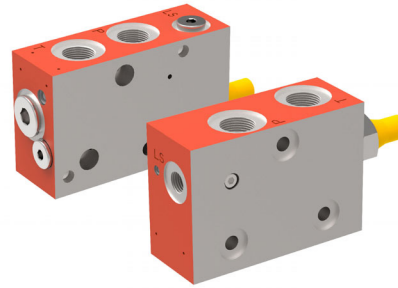

3.2.2 Technical data

General characteristics	Unit	Description, value
Inlet pressure	PSI (bar)	max. 4351 (max. 300)
Nominal flow rate	GPM (l/min)	see performance graphs 3.2.3
Pressure relief	PSI (bar)	adjustable

3.2.3 Performance graphs

3.2.3.1 Inlet pressure relief two-stage LU8SPOD

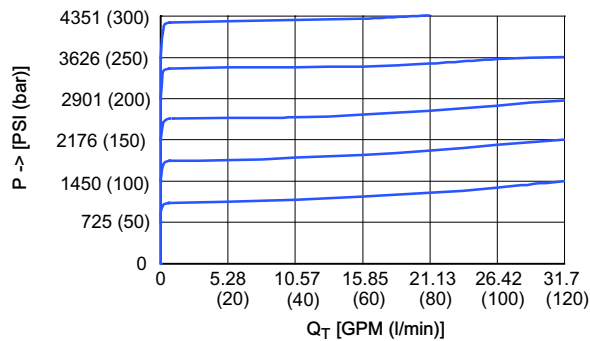

3.2.3.2 Inlet pressure relief direct acting LU8SPOS

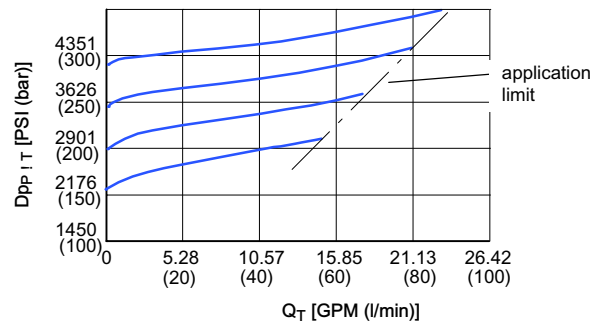

3.2.4 Overview of sections

3.2.4.1 Inlet pressure relief two-stage

Symbol	Description	Part number
	LU8SPOD-0U78 P= <ul style="list-style-type: none"> relief adjustment range 870 ... 4351 PSI (60 ... 300 bar) nominal flow rate 31.7 GPM (120 l/min) port threads to ISO 11926: 7/8"-14 UNF-2B ⇒ Specify the pressure relief setting in bar (Example: LU8SPOD-0U78 P=200)	100030560

3.2.4.2 Inlet pressure relief direct acting

Symbol	Description	Part number
	<p>LU8SPOS3-0U78 P=</p> <ul style="list-style-type: none"> • application limit see performance graph • relief adjustment range 3046 ... 4351 PSI (210...300 bar) P = • port threads to ISO 11926: 7/8"-14 UNF-2B <p>⇒ Specify the pressure relief setting in bar, (35...95 bar) (Example: LU8SPOS3-0U78 P=200)</p>	See order details chapter 1.1

3.2.5 Dimensions [in (mm)]

3.2.5.1 LU8SPOD-...

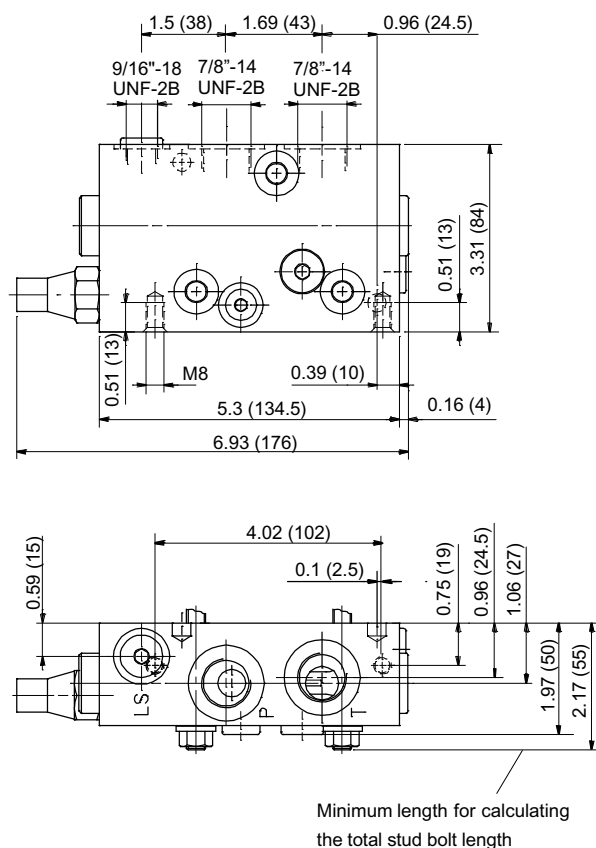

3.2.5.2 LU8SPOS-...

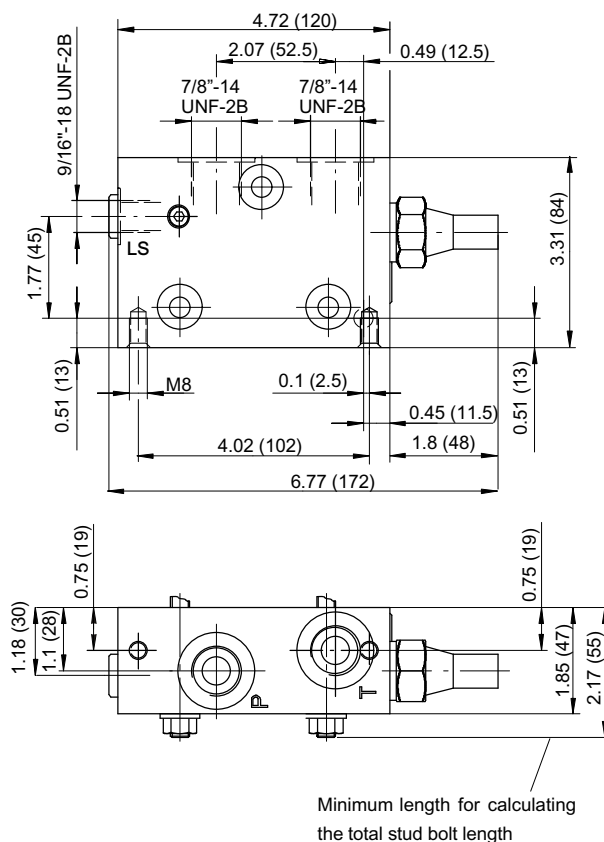

3.3 Inlet section with 2-way compensator

3.3.1 Description

These are used to begin the block and have an integral 2-way compensator; optionally with flow cut-off from a pre-set pressure. A typical application is the parallel operation of two valve blocks in an LS-system, where only one spool at a time is operated within each block.

Ports P and LS, and tapped holes for securing the valve block are provided. The tank connection must be implemented in the intermediate or end section.



3.3.2 Technical data

General characteristics	Unit	Description, value
Inlet pressure	PSI (bar)	max. 4351 (300)
Nominal flow rate / open-centre systems	GPM (l/min)	26.42 (100)
Pressure relief	PSI (bar)	adjustable, 725 ... 4351 (50 ... 300)

3.3.3 Performance graphs

3.3.3.1 Variation of the actuator flow rate with inlet pressure when using an LU8SSKB inlet section

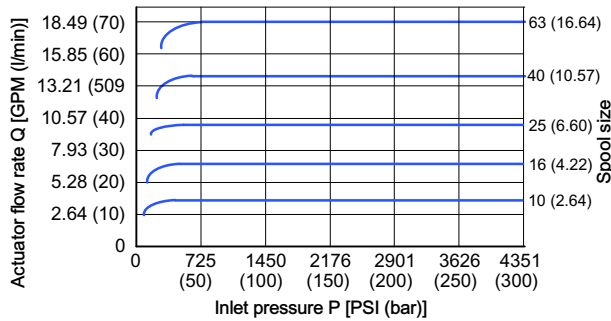

3.3.3.2 Flow cut-off function with an LU8SSKB inlet section

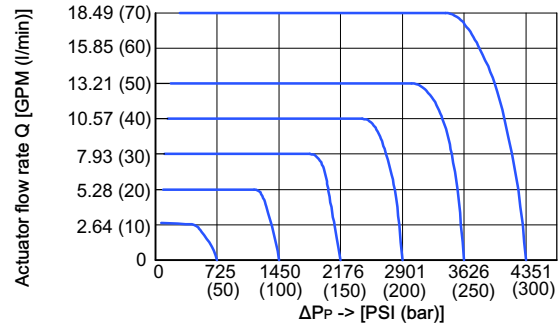

3.3.4 Overview of sections

Symbol	Description	Part number
	LU8SSKB-0U78 P= • control $\Delta p = 174$ PSI (12 bar) • with flow cut-off ⇒ Specify the pressure relief setting in bar	100036400

3.3.5 Dimensions [in (mm)]

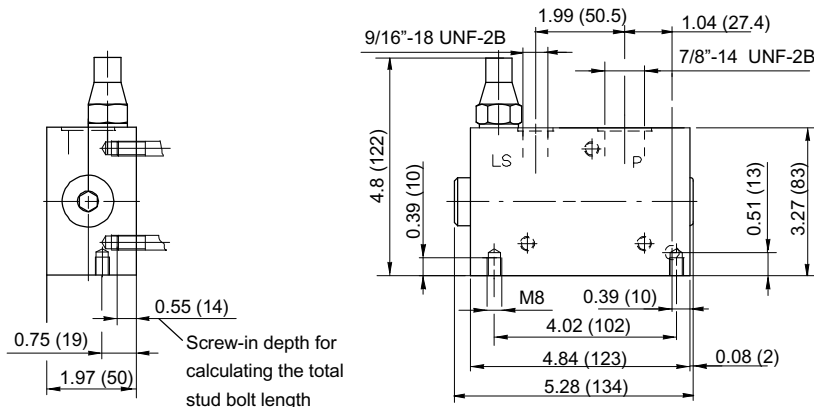

3.4 Inlet section with 3-way compensator

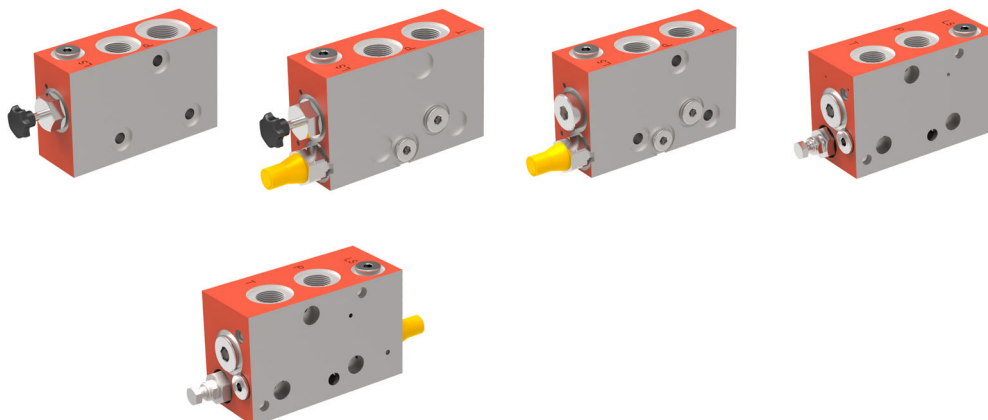

3.4.1 Description

These are used to begin the block and have an integral 3-way compensator; optionally with the additional functions shown below. These inlets are used with fixed displacement pumps.

In essence, they can be applied in conjunction with a fixed-displacement pump for control of unloading and flow control that is independent of the load.

- **LU8SSCK**
Provides a 3-way compensator function with the facility to change over to LS- or constant pressure systems. This is typical with towed harvesters.
- **LU8SSCL**
Provides a 3-way compensator function and two-stage pressure relief that is adjustable from outside the valve, with the ability to change over to LS or constant-pressure systems. This is typical with towed harvesters. The pressure relief is only operative in the open system.
- **LU8SSCS**
Provides a 3-way compensator function and 2-stage pressure relief that is adjustable from outside the valve.
- **LU8SSCU**
Provides a 3-way compensator function with an independent system pressure relief function.
- **LU8SSCX**
Provides a 3-way compensator function and two-stage pressure relief that is adjustable from outside the valve, and an independent system pressure relief function. The surplus flow is available at port D for other applications. The valve block's own functions have priority over port D. The valve block can be protected at a lower pressure setting by the two-stage relief valve, so that excess flow is always available at port D.

3.4.2 General technical data

General characteristics	Unit	Description, value
Inlet pressure	PSI (bar)	max. 4351 (max. 300)
Nominal flow rate	GPM (l/min)	31.70 (120)
Unloaded pressure P -> T (D)	PSI (bar)	see performance graphs chapter 3.4.3
Pressure relief	PSI (bar)	adjustable, 725 ... 4351 ²⁾ (50 - 300)
Nominal voltage ¹⁾	VDC	12 or 24
Plug type		AMP Junior Timer, Deutsch plug DT04-2P-EP04
Power consumption ¹⁾	Watt	27
Duty cycle ¹⁾	%	100
Protection class ¹⁾		AMP: IP65 DT04-2P-EP04: IP67 (DIN EN 60529)

¹⁾ Only with LU8SSCE

²⁾ Higher pressure on request

3.4.3 Performance graphs

3.4.3.1 Maximum flow rate at directional valve (without individual pressure compensator) when using an LU8SSC inlet section.

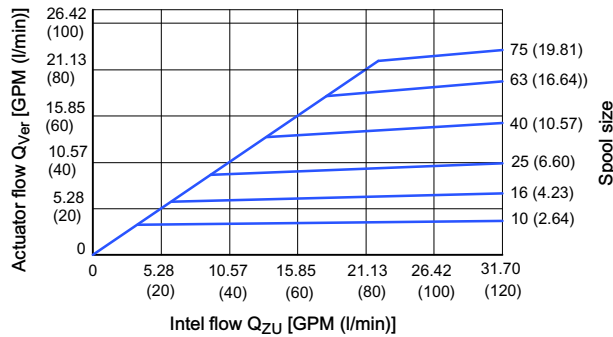

3.4.3.2 Unloaded pressure in neutral position, (for other unloaded pressures consult Bucher Hydraulics).

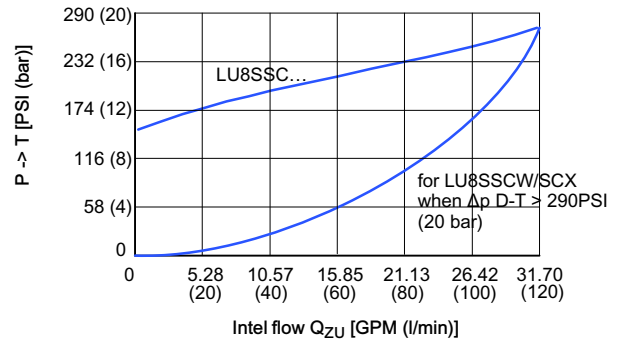

3.4.3.3 Two-stage pressure relief characteristic inlet section LU8SSCS/SCX

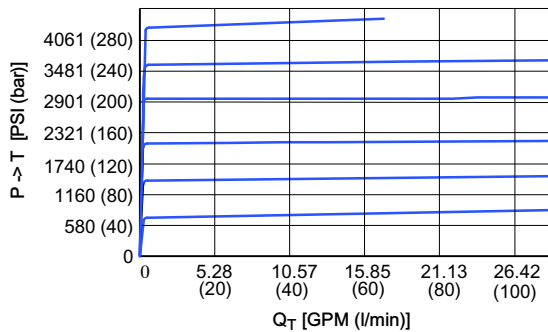

3.4.3.4 System pressure relief characteristic inlet section LU8SSCE/SCU/SCW/SCX

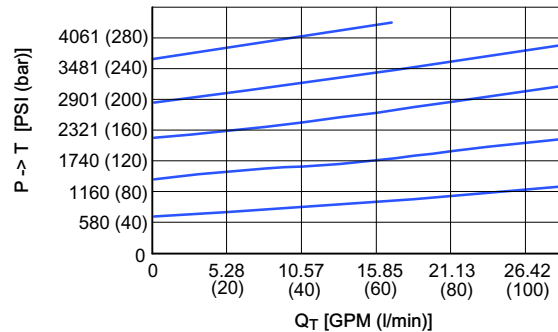

3.4.4 Overview of sections

Symbol	Description	Part number
	LU8SSCK-0U78 <ul style="list-style-type: none"> without pressure relief compensator can be disabled for LS systems control $\Delta p = 174$ PSI (12 bar) with active pressure compensator port threads to ISO 11926: $7/8''$-14 UNF-2B 	100037845
	LU8SSCK-0U78/04 <ul style="list-style-type: none"> without pressure relief compensator can be disabled for LS systems for using with seat valves SVH04M - straight-through tie bolts control $\Delta p = 174$ PSI (12 bar) with active pressure compensator port threads to ISO 11926: $7/8''$-14 UNF-2B 	See order details chapter 1.1
	LU8SSCK-0U78/12 <ul style="list-style-type: none"> without pressure relief compensator can be disabled for LS systems for using with seat valves SVH04M - straight-through tie bolts control $\Delta p = 174$ PSI (12 bar) with active pressure compensator no tank connection for bolt-on functions port threads to ISO 11926: $7/8''$-14 UNF-2B 	See order details chapter 1.1

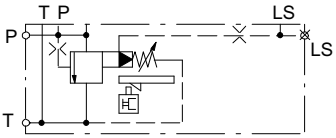
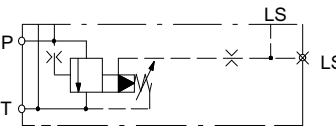
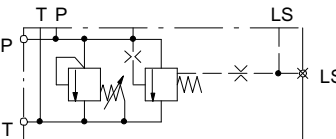
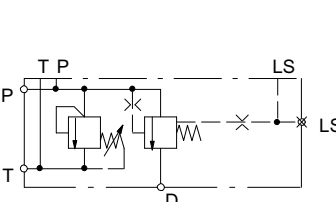
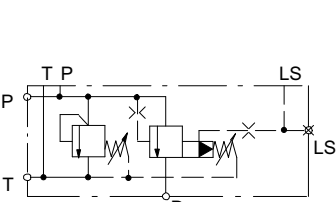
	LU8SSCL-0U78/04 P=	See order details chapter 1.1
	LU8SSCS-0U78/04 P=	100031679
	LU8SSCU-0U78 P=	See order details chapter 1.1
	LU8SSCW-0U78 P=	100029384
	LU8SSCX-0U78 P= P1=	100029848

3.4.5 Dimensions [in (mm)]

3.4.5.1 LU8SSCK / SCS / SCL

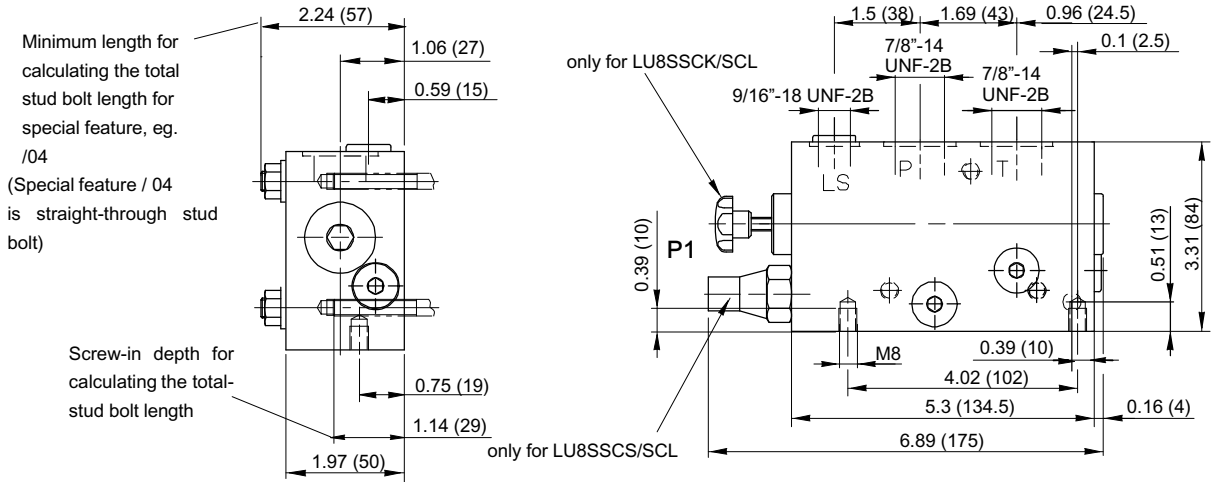

3.4.5.2 LU8SSCU / SCW / SCX

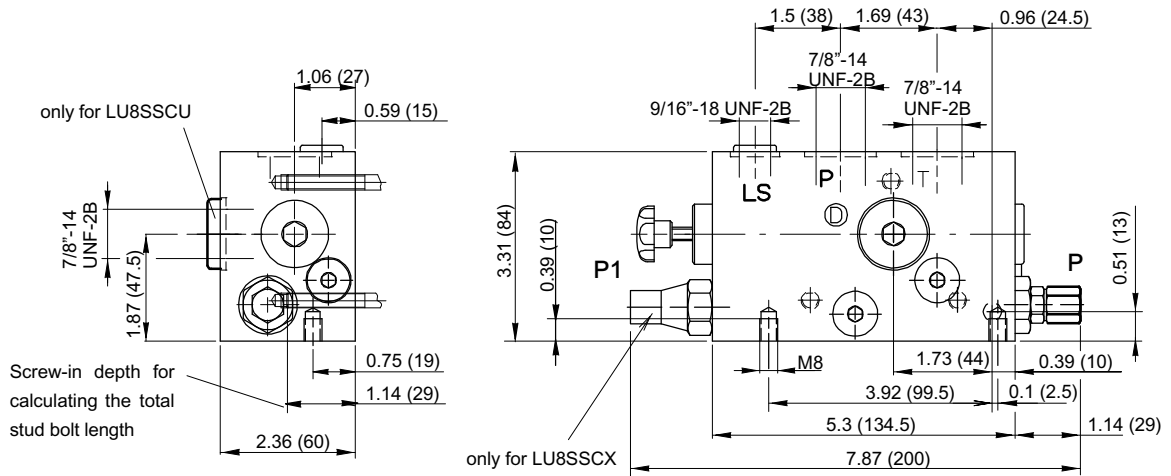

4 Intermediate sections

4.1 Intermediate section with no control function

4.1.1 Description

These intermediate sections are used as spacer section (e.g. with large port fittings) or, in the case of the LU8SBTP-0; for hydraulic partitioning of the P and LS lines within the valve block; T is continuous.

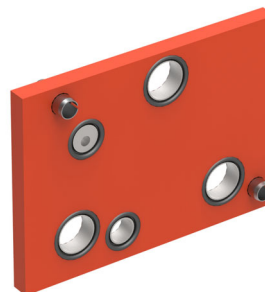

4.1.2 Overview of sections

Symbol	Description	Part number
	LU8SBDP-0 <ul style="list-style-type: none"> • block spacer section • P, T and LS continuous 	100020651

4.1.3 Dimensions [in (mm)]

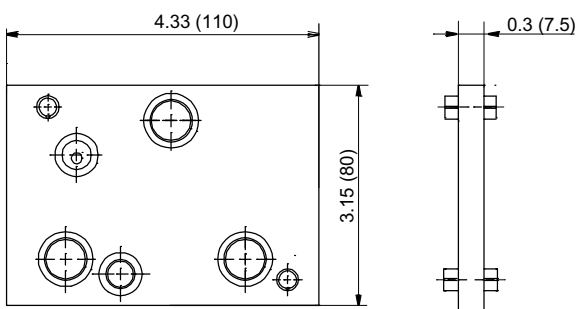

4.2 Intermediate section with 2-way pressure compensator

4.2.1 Description

These are intermediate sections with an integral 2-way pressure compensator, optionally with flow cut-off from a pre-set pressure. Typical applications: valve block sections that, in general, experience lower pressures are combined with this compensator to ensure load-independent operation. Ports P and LS are provided.



4.2.2 Technical data

General characteristics	Unit	Description, value
Inlet pressure	PSI (bar)	max. 4351 (max. 300)
Nominal flow rate	GPM (l/min)	see performance graphs 4.2.3
Pressure relief valve	PSI (bar)	adjustable

4.2.3 Performance graphs

4.2.3.1 Variation of the actuator flow rate with inlet pressure when using an LU8SSKC / SKD intermediate section

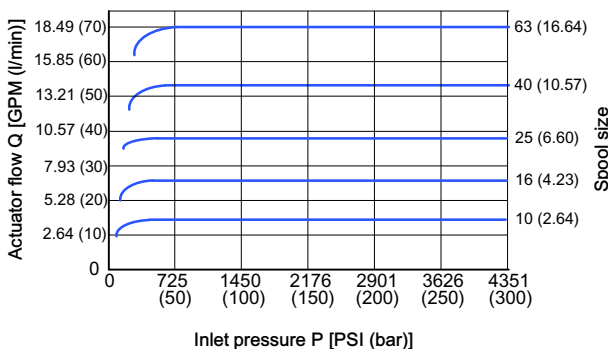

4.2.3.2 Flow cut-off function with an LU8SSKD intermediate section

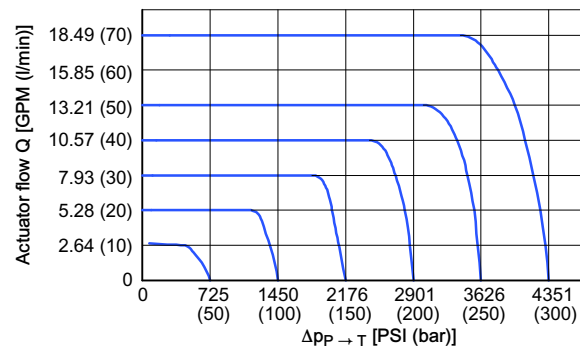

4.2.4 Overview of sections

Symbol	Description	Part number
	LU8SSKD-0U78 P= <ul style="list-style-type: none"> nominal flow rate 26.42 GPM (100 l/min) with adjustable pressure relief valve for flow cut-off port threads to ISO 11926: 7/8"-14 UNF-2B ⇒ Specify the pressure relief setting in bar, (50 ... 300 bar)	see order details chapter 1.1

4.2.5 Dimensions [in (mm)]

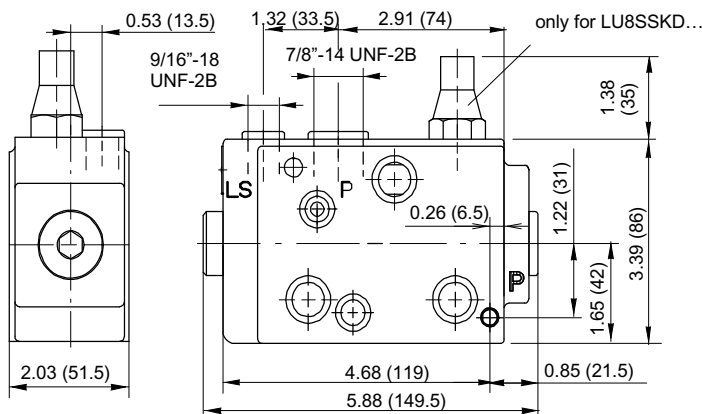

4.3 Intermediate sections with 3-way pressure compensator

4.3.1 Description

These 3-way compensators are intermediate sections with the additional functions shown below. In essence, they can be applied in conjunction with a fixed-displacement pump for control of unloading, and flow control that is independent of the load. Ports P, and D and LS as appropriate, are provided.

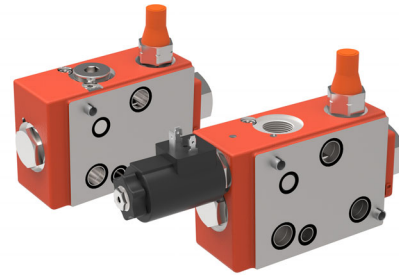

4.3.2 Function

- **LU8SSBU**

Provides a 3-way compensator function with 2-stage pressure relief and a reduction in the unloaded pressure from the standard 174 PSI (12 bar) to approx. 87 PSI (6 bar).

- **LU8SSBW**

Provides a 3-way compensator function and the surplus flow is available at port D or internally for other applications. Both flows are protected by a two-stage pressure relief valve. On reaching the maximum pressure in the priority side, which can then be loaded up to the maximum pressure setting.

4.3.3 Technical data

General characteristics	Unit	Description, value
Inlet pressure ¹⁾	PSI (bar)	max. 4351 (max. 300)
Nominal flow rate	GPM (l/min)	31.7 (120)
Unloaded pressure P -> T (LU8SSBU/SBT/SBL/SBK)	PSI (bar)	see performance graphs chapter 4.3.4
Pressure relief	PSI (bar)	adjustable, 725 ... 4351 (50 ... 300)
Nominal voltage ²⁾	VDC	12 or 24
Plug type		AMP Junior Timer, DT04-2P-EP04
Power consumption ²⁾	Watt	27
Duty cycle ²⁾	%	100
Protection class ²⁾		AMP: IP65 DT04-2P-EP04: IP67 (DIN EN 60529)

1) Inlet pressure for LU8SSBU-....G.. and LU8SSBW-....G.. max. 3626 PSI.

2) Only with electrical unloading.

4.3.4 Performance graphs

4.3.4.1 Unloaded pressure in neutral position, LU8SBW

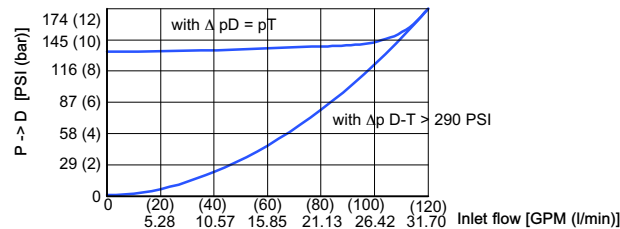

4.3.4.3 Pressure relief characteristic LU8SSB

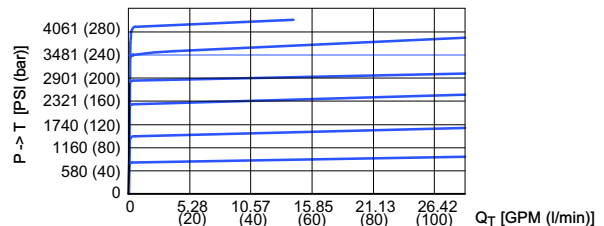

4.3.4.2 Maximum flow rate at directional valve (without individual pressure compensator) when using an LU8SSBU / LU8SSBW

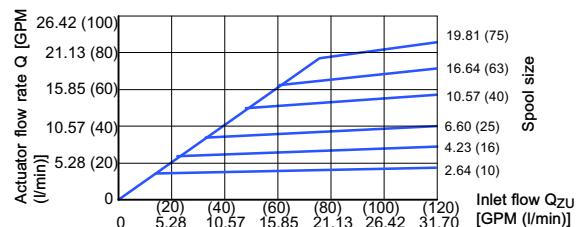

4.3.5 Overview of sections

Symbol	Description	Part number
	LU8SSBU-0U78 P= <ul style="list-style-type: none"> with two-stage pressure relief / control $\Delta p = 174 \text{ PSI (12 bar)}$ reduction in the unloaded pressure to approx. 87 PSI (6 bar) port threads to ISO 11926: $7/8''\text{-}14 \text{ UNF-}2\text{B}$ ⇒ Specify the pressure relief setting in bar	see order details chapter 1.1
	LU8SSBW-0U78 P= <ul style="list-style-type: none"> with two-stage pressure relief / with surplus flow port control $\Delta p = 174 \text{ PSI (12 bar)}$ port threads to ISO 11926: $7/8''\text{-}14 \text{ UNF-}2\text{B}$ ⇒ Specify the pressure relief setting in bar	see order details chapter 1.1
	LU8SSBW-0U78T24 P= <ul style="list-style-type: none"> with two-stage pressure relief / with surplus flow port control $\Delta p = 174 \text{ PSI (12 bar)}$ / emergency stop function port threads to ISO 11926: $7/8''\text{-}14 \text{ UNF-}2\text{B}$ plug type to DIN 43650 (others on request) / nominal voltage 24 VDC ⇒ Specify the pressure relief setting in bar	see order details chapter 1.1

4.3.6 Connector socket

AMP Junior Timer J	Deutsch plug DT04-2P-EP04 T

4.3.7 Dimensions [in (mm)]

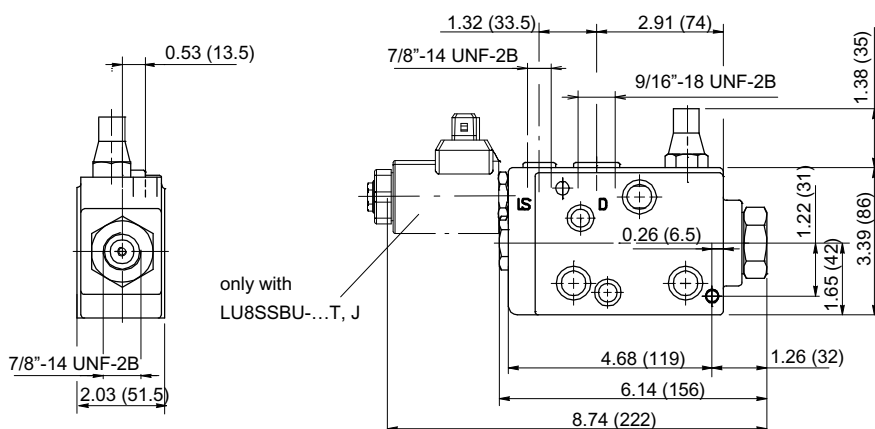

4.4 Intermediate sections with multi-way pressure compensator

4.4.1 Description

The multi-way pressure compensators contain a priority function for the directional valves fitted on the appropriate side. For the surplus-flow side, a 3-way pressure compensator is available for unloading control and load-independent flow control when using a fixed displacement pump.

In the under-supply range (pump flow < total flow needed by the valve block), the surplus flow side will receive only a portion of what it needs, or possibly (pump flow < priority flow setting) no flow whatsoever.

Application preferably in conjunction with a fixed displacement pump, but with the ability to change over to LS or constant-pressure systems.

Ports P, T, and LS are provided.

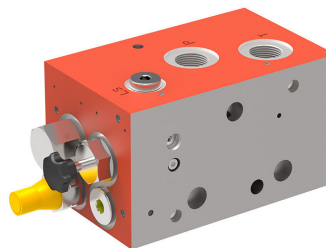

4.4.2 Functions

- **LU8SSMF**

Priority-flow control as 2- and 3-way compensator, with surplus-flow control as 3-way compensator. The priority-flow side is provided with a flow cut-off function. The surplus-flow control can be de-activated, which allows an LS- or constant-pressure system to be connected. This is typical with towed harvesters.

4.4.3 Technical data

General characteristics	Unit	Description, value
Inlet pressure	PSI (bar)	max. 4351 (max. 300)
Nominal flow rate	GPM (l/min)	31.7 (120)
Unloaded pressure	PSI (bar)	see performance graphs section 4.5.4
Pressure for flow cut-off (P_{Priority})	PSI (bar)	adjustable, pressure range 725 ... 4351 PSI (50 ... 300 bar)
Pressure for pressure relief (P_{Surp})	PSI (bar)	adjustable, pressure range 725 ... 4351 PSI (50 ... 300 bar)

4.4.4 Performance graphs

4.4.4.1 Maximum flow rate at directional valve when using an LU8SSM. (priority- and surplus side).

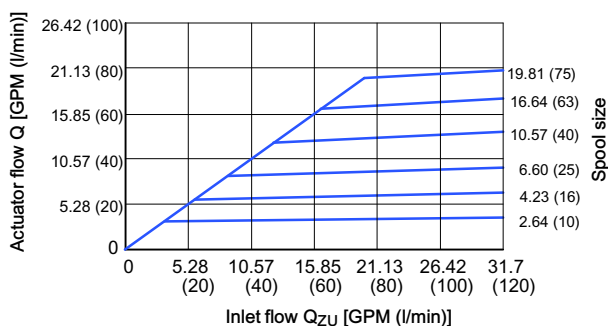

4.4.4.2 Flow cut-off on the priority side

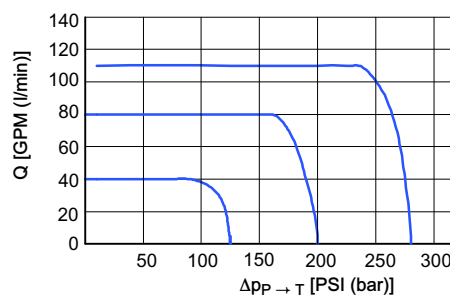

4.4.4.3 Pressure relief characteristic (priority and surplus flow) intermediate section LU8SSM

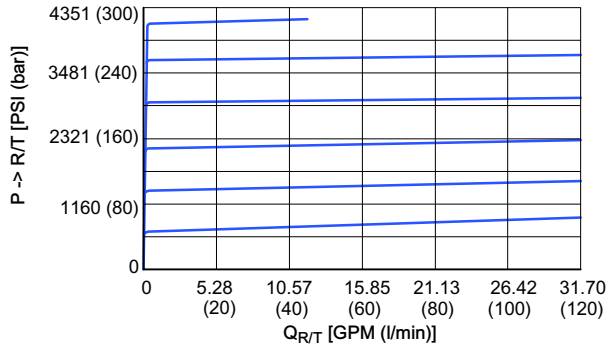

4.4.4.4 Unloaded pressure in neutral position intermediate section LU8SSM

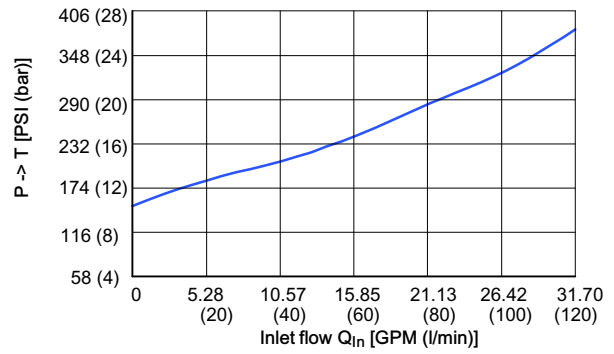

4.4.5 Overview of sections

Symbol	Description	Part number
	LU8SSMF-0U78 P= <ul style="list-style-type: none"> • P_{Prior} with pressure relief • compensator can be disabled on surplus-flow side for LS systems • control $\Delta p = 174 \text{ PSI (12 bar)}$ for P_{Prior} • control $\Delta p = 174 \text{ PSI (12 bar)}$ for P_{Rest} with active pressure compensator • port threads to ISO 11926: 7/8"-14 UNF-2B ⇒ Specify the pressure relief setting in bar	-

4.4.6 Dimensions [in (mm)]

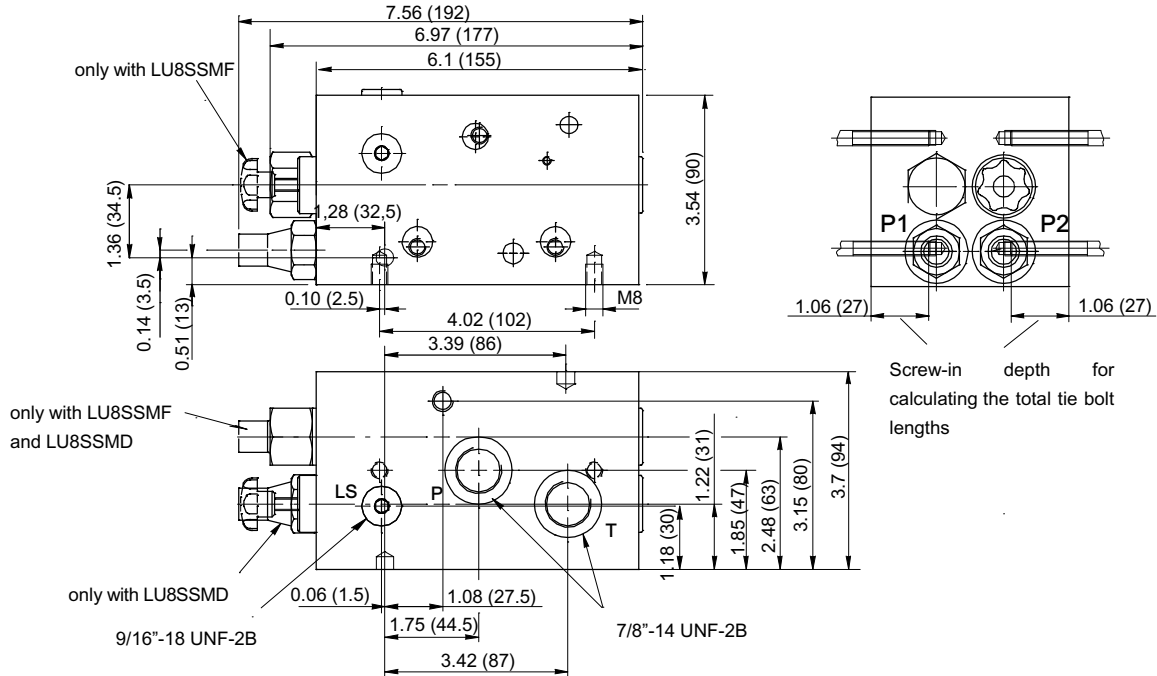

5 Directional valves

5.1 LD8S- /LC8S-Directional valve

5.1.1 Description

These directional valve sections with direct-acting ON/OFF solenoid or proportional solenoid are distinguished by their adaptability. Auxiliary functions can be bolted on above or below the valve. To enable this, the appropriate interfaces must be chosen (see following illustrations).

It is possible to set either the opening point of the control spool, or any predetermined point on the characteristic.

In the version with an additional manual operator, the flow rate can be increased.

The setting of the additional manual operator has no effect on the electrical operation. During electrical operation, the additional manual operator is not carried along with the solenoid mechanism. The lever remains in its neutral position, and thus has no influence on the spool characteristic.



5.1.1.1 Integral auxiliary functions

- Individual pressure compensator

The integral 2-way pressure compensator maintains a constant pressure differential over the metering orifice in the directional valve spool. This means that the corresponding actuator flow remains constant and load-independent even if another actuator that needs a higher pressure is operated at the same time.

- Flow cut-off

Thanks to the adjustable maximum pressure, the actuator flow rate is reduced to zero when the level is exceeded. The corresponding function therefore stops until the actuator pressure has fallen to the permissible pressure range.

The pressure adjustment is manual, or optionally electro-proportional.

- 3-way pressure control

Both a 3-way pressure control (P constant) and a flow control (Q constant) are incorporated in this valve section. The integral pressure control function can be switched to actuator port A or B, depending on the switching position of the valve section.

Below the pressure setting, the pressure-control assembly works as an individual pressure compensator and maintains a constant pressure differential over the metering orifice in the directional valve spool.

This means that the actuator flow rate is load-independent. For optimum 3-way pressure control, the corresponding directional function must be activated to its maximum extent.

Typical applications are actuating functions that are specifically speed-controlled, with the possibility of a holding or press function. This function can be controlled to any required pressure and can act optionally on either actuator A or B.

5.1.2 Function

5.1.2.1 LD8S with direct-acting ON/OFF solenoid

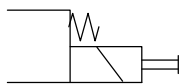

5.1.2.2 LD8S with direct-acting ON/OFF solenoid, optional manual override for the valve spool



The flow rates to the A and B actuator ports are graded by spool size as per sections 5.2.4. Using the stop-screw on the non-active solenoid, each flow rate can be reduced from its maximum by a maximum of 50%.

5.1.2.3 LC8S with direct-acting proportional solenoid

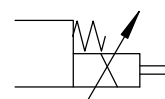

5.1.2.4 LC8S with direct-acting proportional solenoid, optional manual override for the valve spool

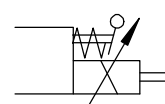

The flow rates to the A and B actuator ports are graded by spool size as per sections 5.2.4.

5.1.3 Technical data

General characteristics	Unit	Description, value	
		LD8S	LC8S
Type of operation	PSI (bar)	ON/OFF	Proportional
Inlet pressure	PSI (bar)	3626 (250)	
Actuator pressure (duty cycle 10 sec/min)	PSI (bar)	max. 4061 (max. 280)	
Spool size	GPM (l/min)	0.53 (02) / 1.32 (05) / 2.64 (10) / 4.23 (16) / 6.6 (25) / 10.57 (40) / 15.85 (60)	
Solenoid design		ON/OFF solenoid with mechanical manual override	Proportional solenoid with mechanical manual override
Nominal voltage	VDC	12 (10.8 ... 14) 24 (21.6 ... 28)	12 or 24
Power consumption at R ₂₀	Watt	22 (U _N 12 V) 22 (U _N 24 V)	max. 24 at 2.5 A (U _N 12 VDC) max. 24 at 1.3 A (U _N 24 VDC)
Duty cycle	%	100	100 at I _{max} 2.5 A (U _N 12 VDC) 1.13 A (U _N 24 VDC)
Plug type		AMP Junior Timer with protective diode P6KE33CA, DT04-2P-EP04	
Enclosure protection		AMP: IP65	DT04-2P-EP04: IP67 (DIN EN 60529)
Switch frequency	Hz	> 2 (please contact the factory)	
Accessories			For electronic controls see overview brochure P70003

IMPORTANT: Maximum reduction is to 50% of the respective nominal spool size.

5.1.4 Performance graphs

5.1.4.1 Typical flow characteristic curve without compensator function (spool 4D)

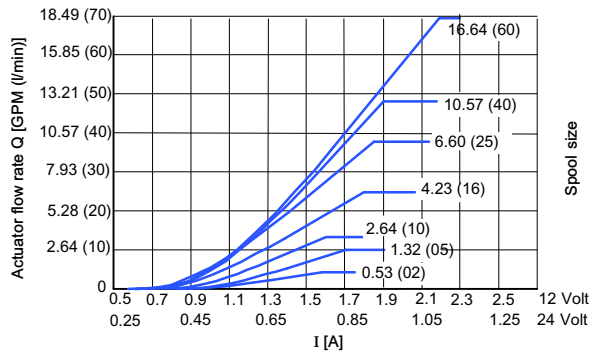

5.1.4.2 Typical flow characteristic curve with compensator function (spool 4D)
(Inlet section with 3-way pressure compensator for Δp 12 bar)

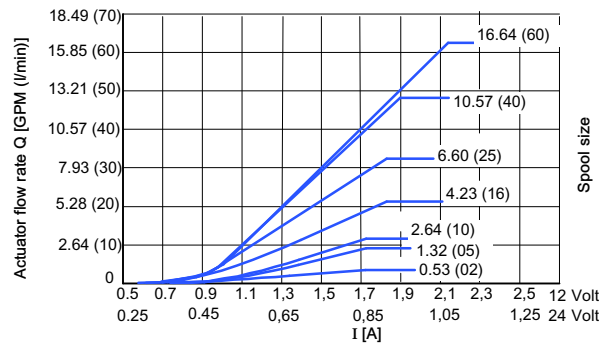

5.1.4.3 LD/LC
Maximum flow rate at the directional valve without compensator function, LS-function

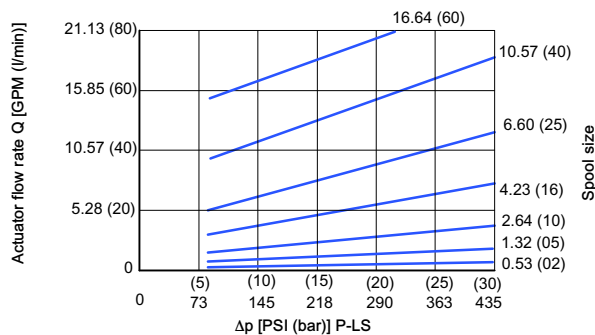

5.1.4.4 LC
Pressure drop A/B -> T in the LC8SM4A directional stage

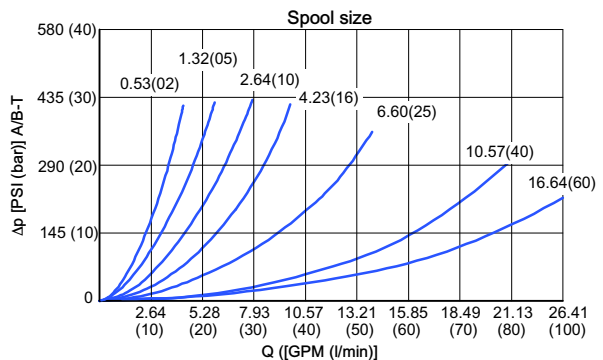

5.1.4.5 Typical flow characteristic curve with flow cut-off function, pressure relief adjustable (manual)

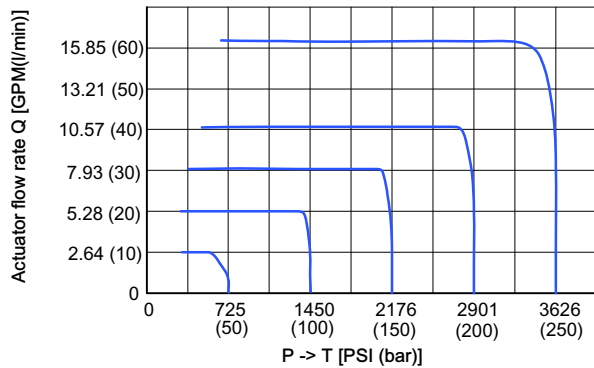

5.1.4.6 Typical flow characteristic curve with flow cut-off function, pressure relief adjustable (electr. prop.)

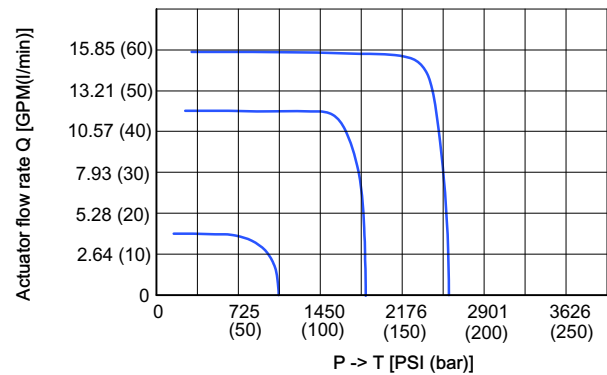

5.1.4.7 LC flow cut-off function pressure setting p - I (electr. prop.)

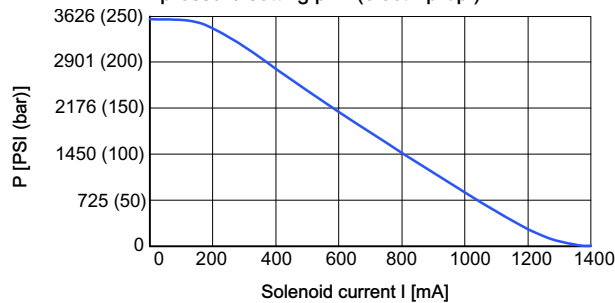

5.1.4.8 Typical pressure profile, 3-way pressure control Electroproportional

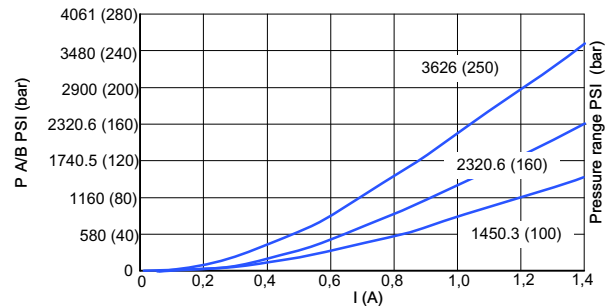

Inverse function possible – please enquire.

5.1.4.9 Typical pressure profile, 3-way pressure control, Overall function

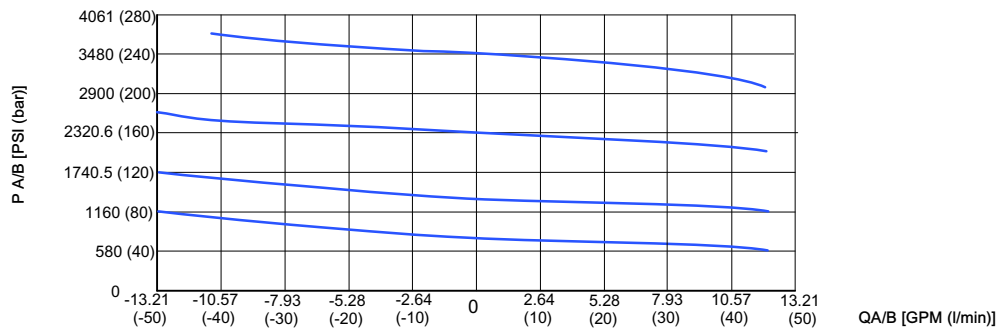

5.1.5 Overview of sections

5.1.5.1 LD8S / LC8S-directional valves with port threads

Symbol	Description	Part number
	<p>L.8SE.....-.*O-....</p> <ul style="list-style-type: none"> port threads for actuator A and B 	see ordering code
	<p>L.8SM.....-.*I-....</p> <ul style="list-style-type: none"> port threads for actuator A and B pressure compensator 	see ordering code

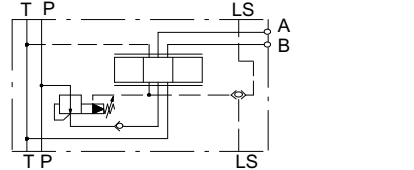
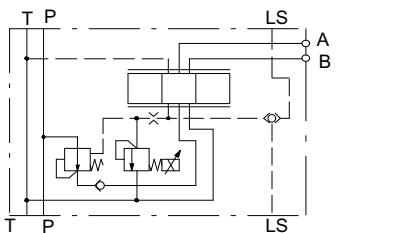
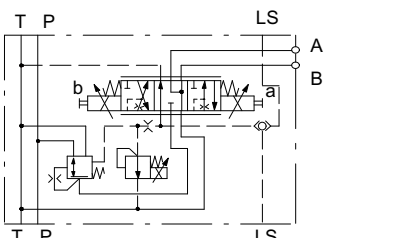
	<p>L.8SM.....-L-....</p> <ul style="list-style-type: none"> port threads for actuator A and B flow cut-off 	<p>see ordering code</p>
	<p>L.8SM.....-P-....</p> <ul style="list-style-type: none"> port threads for actuator A and B pressure compensator flow cut-off electroproportional 	<p>see ordering code</p>
	<p>L.8SM.....-4-....</p> <ul style="list-style-type: none"> port threads for actuator A and B pressure compensator 3-way pressure control 	<p>see ordering code</p>

5.1.5.2 LD8S / LC8S-directional valves for bolt-on auxiliary valves

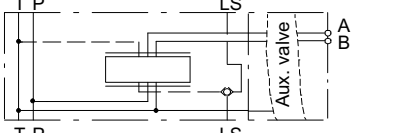
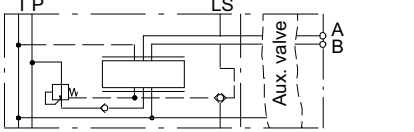
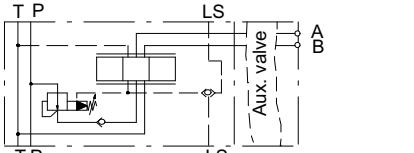
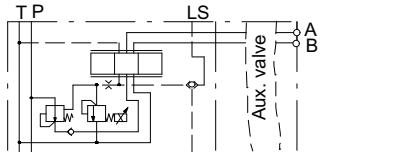
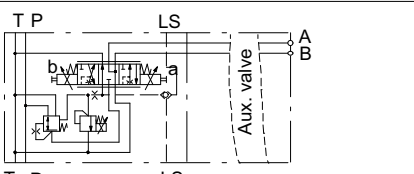
Symbol	Description	Part number
	<p>L.8SE.....-MO-....</p> <ul style="list-style-type: none"> for bolt-on auxiliary valves on flange face O 	<p>see ordering code</p>
	<p>L.8SM.....-MI-....</p> <ul style="list-style-type: none"> for bolt-on auxiliary valves on flange face O flow cut-off 	<p>see ordering code</p>
	<p>L.8SM.....-ML-....</p> <ul style="list-style-type: none"> for bolt-on auxiliary valves on flange face O pressure compensator flow cut-off 	<p>see ordering code</p>
	<p>L.8SM.....-MP-....</p> <ul style="list-style-type: none"> for bolt-on auxiliary valves on flange face O integrated individual pressure compensator flow cut-off, electroproportional 	<p>see ordering code</p>
	<p>L.8SM.....-M4-....</p> <ul style="list-style-type: none"> for bolt-on auxiliary valves on flange face O pressure compensator 3-way pressure control 	<p>see ordering code</p>

5.1.6 Option menu for ordering code (ordering code see section 5.2.9)

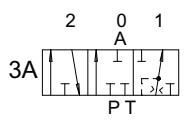
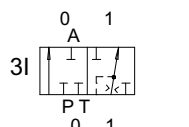
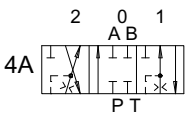
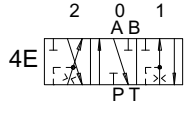
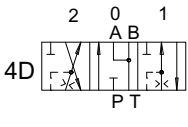
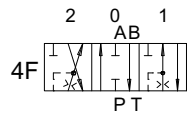

Spool type (way function, spool function, spool size in GPM (l/min))	
 <p>3A</p>	 <p>3I</p>
 <p>4A</p>	 <p>4E</p>
 <p>4D</p>	 <p>4F</p>



Control type	ON/OFF solenoid = LD8S proportional solenoid = LC8S
Operation	load-independent individual operation = E load-independent parallel operation = M
Additional operator	spool stroke limiter (only LD8S) = S manual override = N
Attachment to connection face O	port threads for line connections = * flange face for auxiliary valve = M
Compensator function	without pressure compensator = O with pressure compensator = I with pressure compensator and flow cut-off = L with pressure compensator, electr. proportional flow cut-off = P with pressure compensator and 3-way pressure control = 1 1 = up to 580 PSI (40 bar) 2 = up to 1450 PSI (100 bar) 3 = up to 2321 PSI (160 bar) 4 = up to 3626 PSI (250 bar)
Type of connection at face O	flange face to factory standard = *** line connection to port A and B: ISO 11926: 3/4"-16 UNF 2B =U34

Nominal voltage	12 V DC = 12 24 V DC = 24
Connector socket	AMP Junior Timer = J DT04-2P-EP04 = T

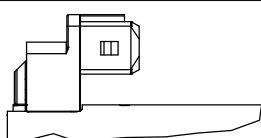
5.1.7 Connector socket

AMP Junior Timer with protective diode P6KE33CA J	DT04-2P-EP04 T
	

5.1.8 Dimensions [in (mm)]

5.1.8.1 LD8S / LC8S core tube

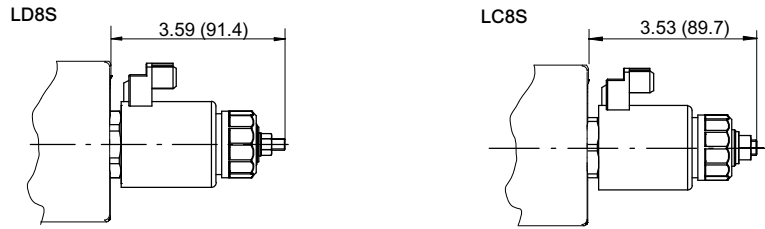

5.1.8.2 LD8S-directional valve

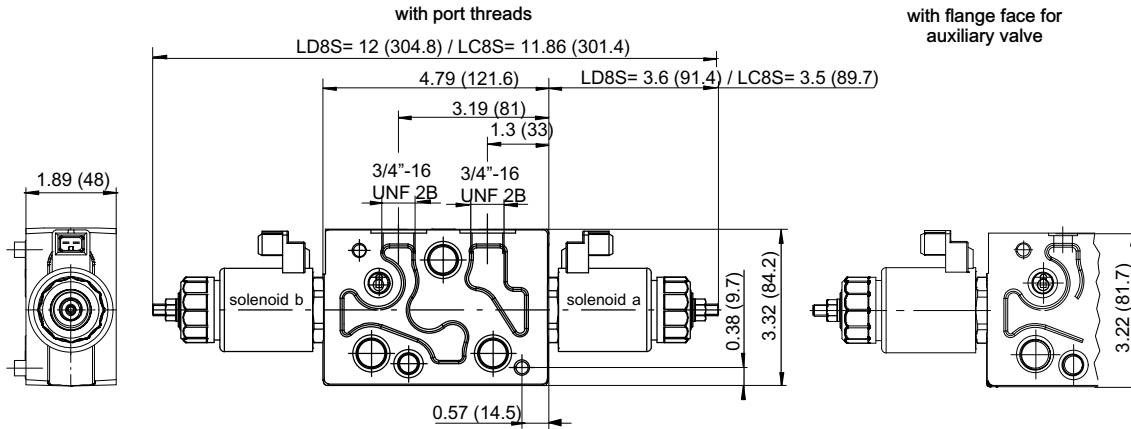

5.1.8.3 LD8SM / LC8SM-directional valve with integrated pressure compensator

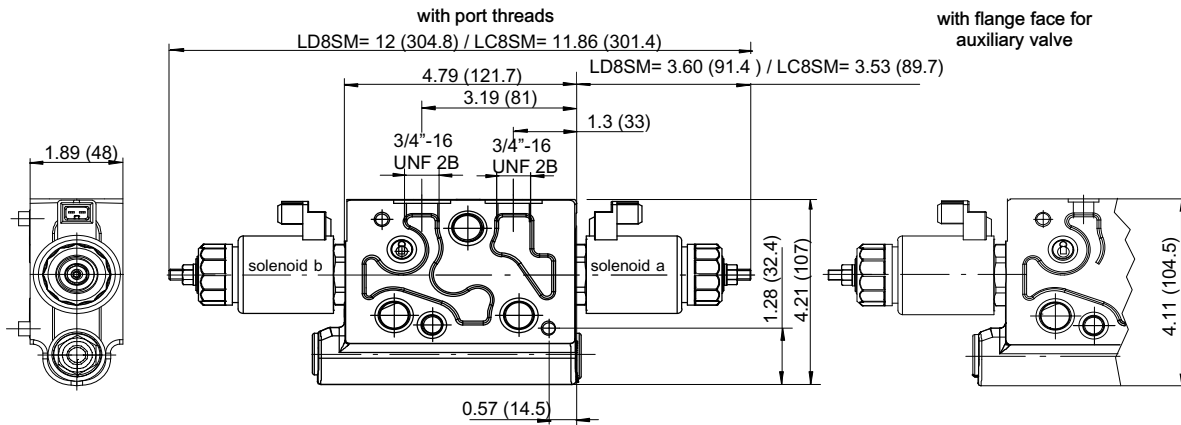

5.1.8.4 LD8S / LC8S-directional valve with integrated pressure compensator and flow cut-off

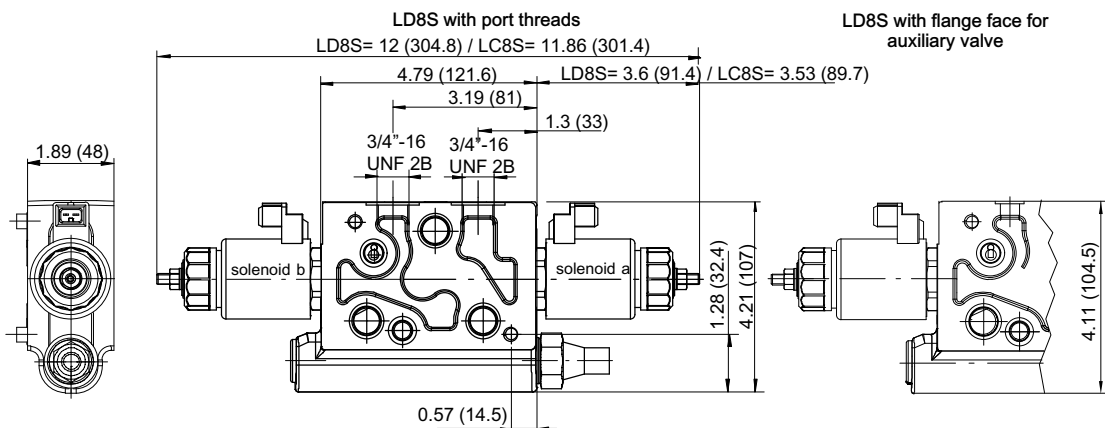

5.1.8.5 LD8S / LC8S-directional valve with manual override

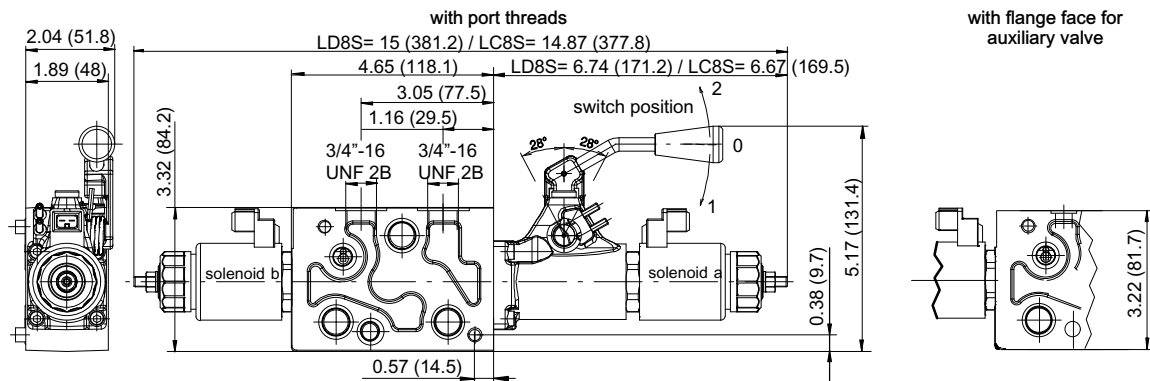

5.1.8.6 LD8S / LC8S-directional valve with manual override, pressure compensator and flow cut-off

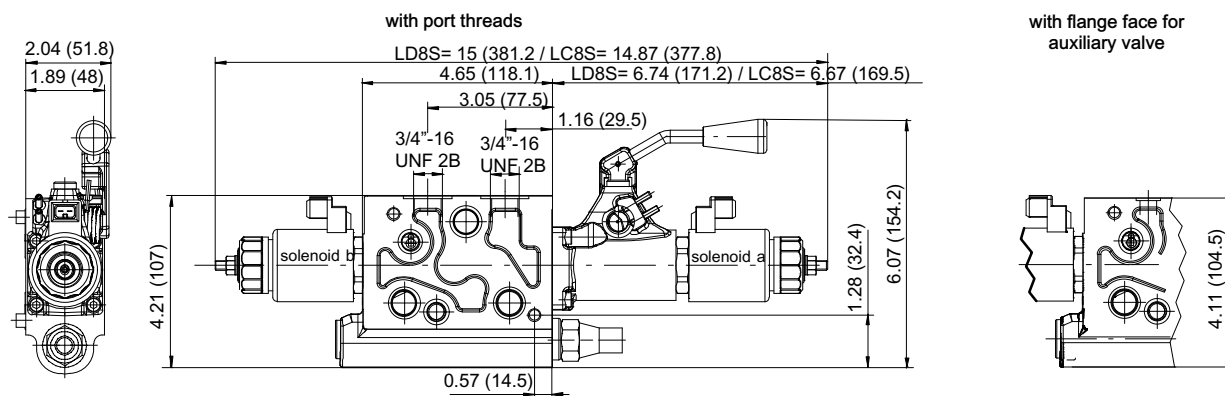

5.1.8.7 LD8S / LC8S-directional valve with pressure compensator, electrically-proportionally flow cut-off

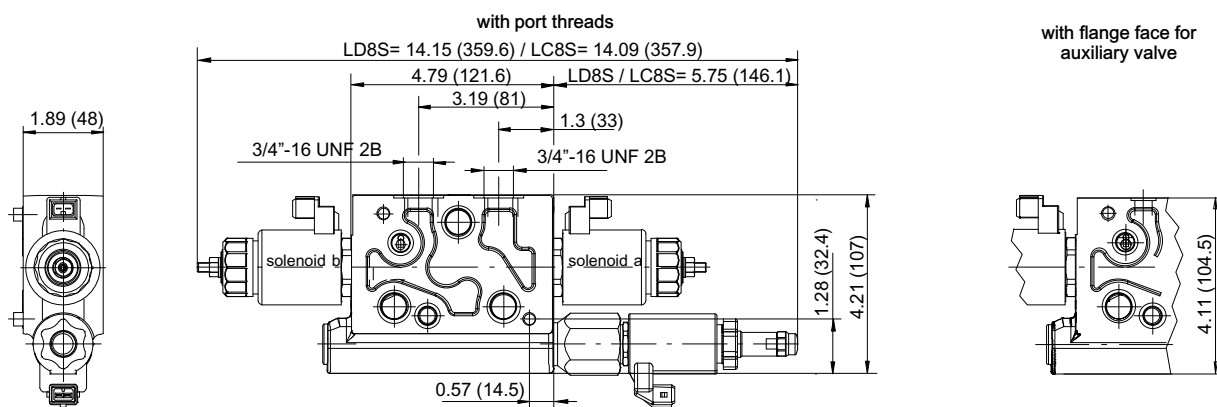

5.1.8.8 LD8S / LC8S-proportional valve with pressure compensator and 3-way pressure control

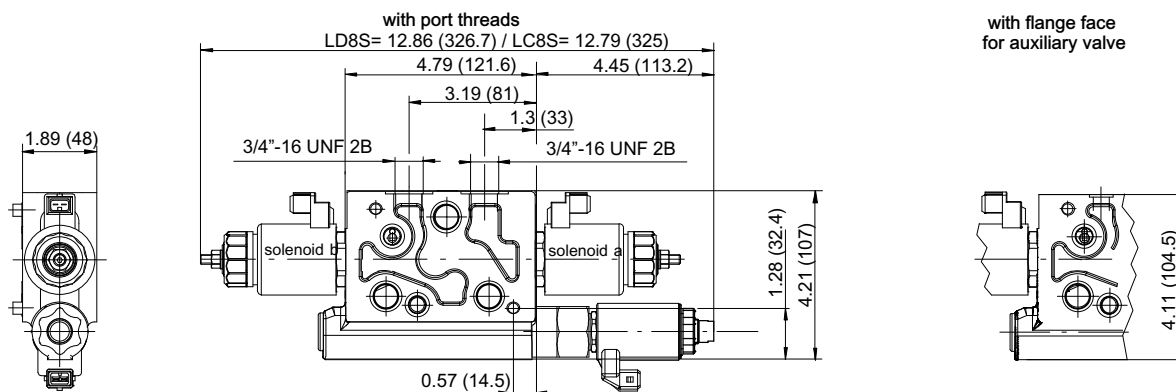



5.1.9 Ordering code

- White fields = data specified by Bucher Hydraulics
- Grey fields = fill out the fields according the option menu 5.2.6

	L	D	8	S	E	3	A	1	0	*	*	-	S	*	O	-	0	U	3	4	J	1	2		
ON/OFF solenoid = LD8S Proportional solenoid = LC8S																									
Load-independent individual operation = E Load-independent parallel operation = M																									
3-way function = 3 4-way function = 4																									
Spool function = A, D, E, F, I, J																									
Port A spool code: 02 (0.53 GPM), 05 (1.32 GPM) 10 (2.64 GPM), 16 (4.23 GPM), 25 (6.60 GPM) 40 (10.57 GPM), 60 (15.85 GPM) = e.g. 10																									
Port B spool code for 3-way function = ** for 4-way function: 02 (0.53 GPM), 05 (1.32 GPM), 10 (2.64 GPM), 16 (4.23 GPM) 25 (6.60 GPM), 40 (10.57 GPM), 60 (15.85 GPM) = e.g. 10																									
Additional operator: without additional operator (only for LC8S) = * spool stroke limiter (only for LD8S) = S manual override = N																									
Attachment to connection face O: port threads for line connection = * flange face for auxiliary valve = M																									
Compensator function: without pressure compensator = O with integrated pressure compensator = I with pressure compensator and flow cut-off = L with pressure compensator, electrically-proportionally flow cut-off = P with pressure compensator, 3-way pressure control (only up to 40 l/min) = e.g. 2 Information for pressure setting: 1 = up to 580 PSI (40 bar) 2 = up to 1450 PSI (100 bar) 3 = up to 2321 PSI (160 bar) 4 = up to 3626 PSI (250 bar)																									
Design stage (will be inserted by Bucher Hydraulics)																									
Type of connection at face O: flange face to factory standard = *** line connection to port A and B: ISO 11926: 3/4"-16 UNF 2B = U34																									
Connector socket: AMP Junior Timer = J Deutsch plug DT04-2P-EP04 = T																									
Nominal voltage: 12 V DC = 12 24 V DC = 24																									
Option: HPCO/Pressure Beyond for compatibility with 2/2 double-seat valve SVH04 = 02																									

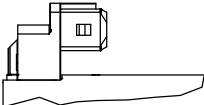
5.1.10 Connector socket

AMP Junior Timer with protective diode P6KE33CA J	Deutsch plug DT04-2P-EP04 T
	

6 Auxiliary valves that bolt-on to the top connection face O

6.1 Anti-shock/make-up valve (secondary pressure relief)

6.1.1 Description

These bolt-on anti-shock/make-up valves are mounted on flange face O. They protect the actuator from unacceptably high pressure peaks.

The excess pressure is discharged to tank. The integral make-up function protects against cavitation. The following combinations are available in the pressure ranges listed.

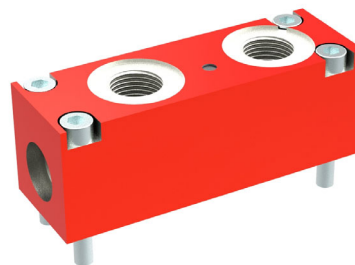

6.1.2 Technical data

General characteristics	Unit	Description, value
Pressure settings available (measured at 2,64 GPM (4 l/min) test flow)	PSI (bar)	1160 (80) / 1450 (100) / 1813 (125) / 2031(140) / 2321 (160) / 2538 (175) / 2756 (190) / 3046 (210) / 3336(230) / 3626 (250) / 4061 (280) / 4351 (300)
Pressure drop through make-up valve	PSI (bar)	58 (4) at 7.93 GPM (30 l/min)
Port threads to ISO 11926		U34 (3/4" -16 UNF-2B)

6.1.3 Overview of sections

Symbol	Description	Part number
<p>Directional valve</p>	LU8SPET-NVONVO-1U34 <ul style="list-style-type: none"> Actuator port A and B: without pressure relief, with make-up valve 	-
<p>Directional valve</p>	LU8SPET-080080-0U34 <ul style="list-style-type: none"> Actuator port A and B: with pressure relief p =1160 PSI (80 bar) with make-up valve 	100032019
<p>Directional valve</p>	LU8SPET-100100-0U34 <ul style="list-style-type: none"> Actuator port A and B: with pressure relief p =1450 PSI (100 bar) with make-up valve 	100032020
<p>Directional valve</p>	LU8SPET-125125-0U34 <ul style="list-style-type: none"> Actuator port A and B: with pressure relief p =1813 PSI (125 bar) with make-up valve 	-
<p>Directional valve</p>	LU8SPET-140140-0U34 <ul style="list-style-type: none"> Actuator port A and B: with pressure relief p =2031 PSI (140 bar) with make-up valve 	-
<p>Directional valve</p>	LU8SPET-160160-0U34 <ul style="list-style-type: none"> Actuator port A and B: with pressure relief p =2321 PSI (160 bar) with make-up valve 	-

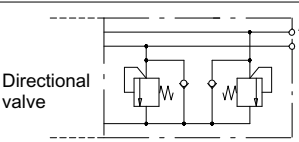
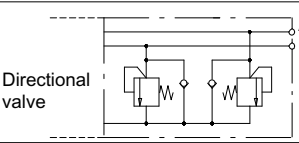
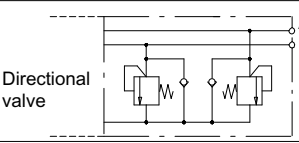
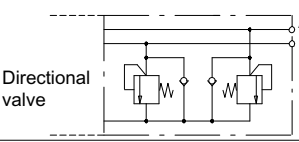
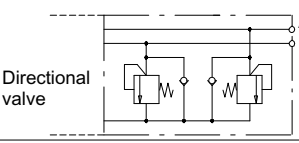
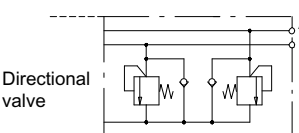
 <p>Directional valve</p>	<p>LU8SPET-175175-0U34</p>	<p>-</p>
 <p>Directional valve</p>	<p>LU8SPET-190190-0U34</p>	<p>-</p>
 <p>Directional valve</p>	<p>LU8SPET-210210-0U34</p>	<p>-</p>
 <p>Directional valve</p>	<p>LU8SPET-230230-0U34</p>	<p>-</p>
 <p>Directional valve</p>	<p>LU8SPET-250250-0U34</p>	<p>-</p>
 <p>Directional valve</p>	<p>LU8SPET-280280-0U34</p>	<p>-</p>

Other on request

6.1.4 Dimensions [in (mm)]

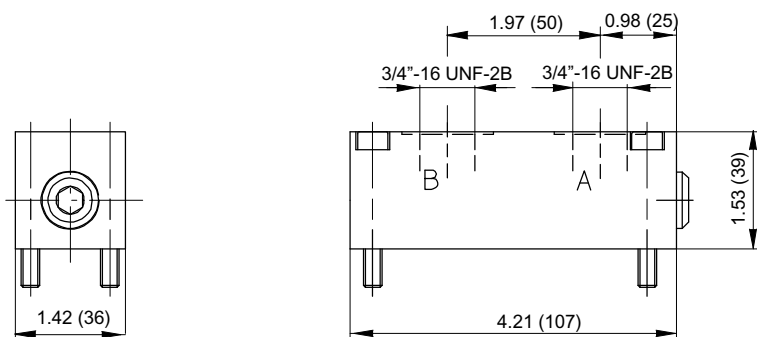

6.2 Check valve (pilot operated non return valve)

6.2.1 Description

These bolt-on check valves with hydraulic or solenoid operation shut off the actuator lines with zero leakage.

The valves must be mounted on connection face O of the directional valve. The following variants are available.

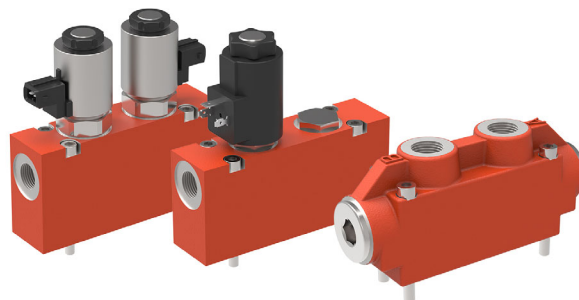

6.2.2 Technical data

General characteristics	Unit	Description, value		
		LU8SPRH...	LU8SPR1-...	LU8SPR2-...
Function		Hydraulic operated	Solenoid operated	Electrohydraulic operated
Nominal flow rate	GPM (l/min)	16.64 (63)	7.93 (30)	18.49 (70)
Operating pressure	PSI (bar)	max. 3626 (250)	max. 3046 (210)	max. 4061 (280)
Actuator pressure	PSI (bar)	max. 4061 (280)	max. 3626 (250)	max. 4351 (300)
Port thread		ISO11926 3/4"-16 UNF-2B		
Ratio of opening pressure to opposing pressure for double-acting cylinders		1 : 6.25 ¹⁾		
Pressure drop	PSI (bar)	102 (7) at 16.64 GPM (63 l/min)	125(10) at 7.93 GPM (30 l/min)	145 (10) at 16.64 GPM(63 l/min)
Nominal voltage	VDC		12 or 24	
Power consumption	Watt		27	22
Duty cycle	%		100	
Enclosure protection			AMP Junior Timer, GDM plug: IP65 Deutsch plug DT04: IP67 (DIN EN 60529)	
Connector socket			GDM plug DIN43650, Deutsch plug DT04-2P-EP04, AMP Junior Timer	

1) Others on request.

6.2.3 Overview of sections

6.2.3.1 LU8SPRH... hydraulic operated, $Q_{max} = 16.64$ GPM (63 l/min)

Symbol	Description	Part number
	LU8SPRH-DVADV-B-0U34 • actuator port A and B: with check valve	100025079
	LU8SPRH-DVA***-0U34 • actuator port A: with check valve • actuator port B: without valve	100025087
	LU8SPRH-***DVB-0U34 • actuator port A: without valve • actuator port B: with check valve	-

Other on request

6.2.3.2 LU8SPR1-... solenoid operation, Q_{max} 7.93 GPM (30 l/min)

Symbol	Description	Part number
	LU8SPR1-DVADV-B-0U34T12 <ul style="list-style-type: none"> actuator port A and B: with check valve connector socket DT04-2P-EP04 nominal voltage 12 VDC 	-
	LU8SPR1-DVADV-B-0U34T24 <ul style="list-style-type: none"> actuator port A and B: with check valve connector socket DT04-2P-EP04 nominal voltage 24 VDC 	-

6.2.3.3 LU8SPR2-... solenoid operation, Q_{max} 18.49 GPM (70 l/min)

Symbol	Description	Part number
	LU8SPR2-DVADV-B-1U34G12 <ul style="list-style-type: none"> actuator port A and B: with check valve connector socket DIN 43650 nominal voltage 12 VDC 	-
	LU8SPR2-DVADV-B-1U34G24 <ul style="list-style-type: none"> actuator port A and B: with check valve connector socket DIN 43650 nominal voltage 24 VDC 	-

6.2.4 Connector socket

AMP Junior Timer J	Deutsch plug DT04-2P-EP04 T

6.2.5 Dimensions [in (mm)]

6.2.5.1 LU8SPRH-...

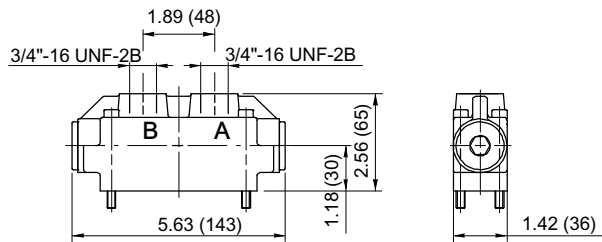

6.2.5.3 LU8SPR2-...

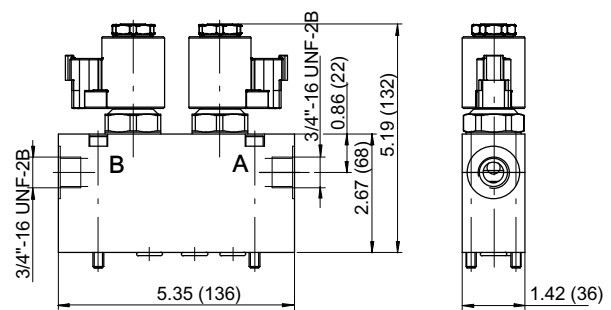

6.2.5.2 LU8SPR1-...

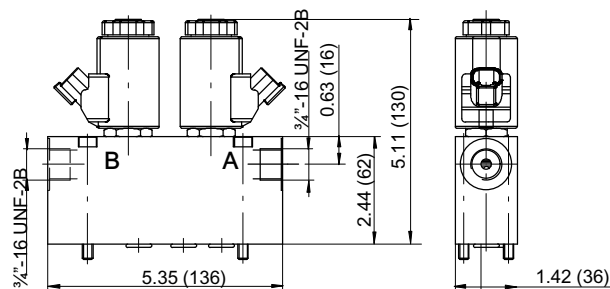

6.3 Load control valve

6.3.1 Description

These bolt-on load control valves with integral anti-shock function ensure load-independent lowering motion at speeds determined by the inlet flow. The load-control valves close without leakage when the directional valve is in its neutral position. The anti-shock valve setting should preferably be 120% of the highest load pressure. Turning the adjusting screw in the clockwise direction reduces the setting, and this can also be used for emergency lowering of the load.

The valves must be mounted on flange face O.
The following variants are available.

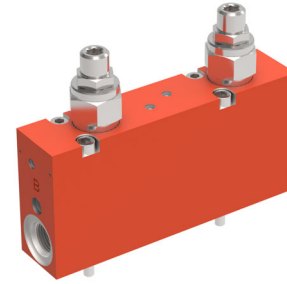

6.3.2 Function

6.3.2.1 LU8SPBH-***E...-...

Load-holding valve at port B, orifice damping facility in the control line. Directional valve spool type 4F preferred.

6.3.2.2 LU8SPBH-E...E...-

Load-holding valves at port A and B. Directional valve spool type 4D preferred.

6.3.3 Technical data

General characteristics	Unit	Description, value
Port threads to ISO 11926		3/4"-16 UNF-2B
Pressure drop	PSI (bar)	200 (13,8) at 15 GPM (56,8 l/min)
Anti-shock valve adjustable	PSI (bar)	1015 ... 4061 (70 ... 280)
Standard pilot ratios		3:1 / 4:1 / 10:1 ¹⁾

1) For other pilot ratios, please enquire.

6.3.4 Overview of sections

Symbol	Description	Part number
	LU8SPBH-E40E40-0U34 P=	100040372
	<ul style="list-style-type: none"> • Actuator port A and B: with load-control, pilot-ratio 4:1 ⇒ Specify the pressure relief setting in bar	
	LU8SPBH-E30E30-0U34 P=	100040373
	<ul style="list-style-type: none"> • Actuator port A and B: with load-control, pilot-ratio 3:1 ⇒ Specify the pressure relief setting in bar	

Other values on request.

6.3.5 Dimensions [in (mm)]

6.3.5.1 LU8SSPBH-***E. / LU8SSPBH-...E..

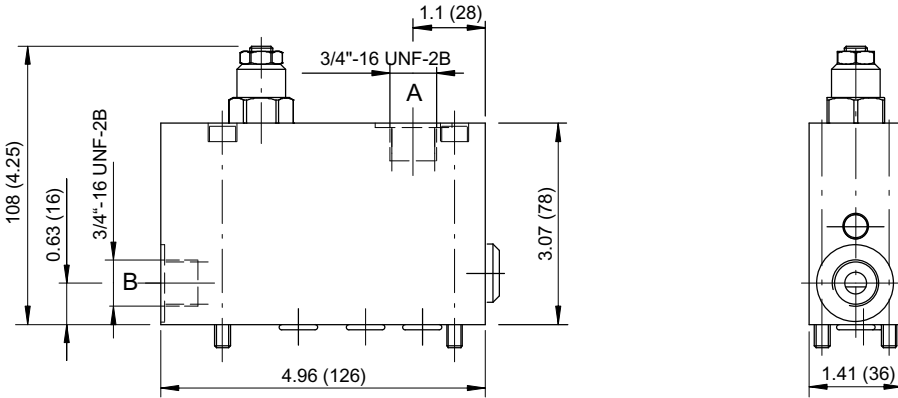

6.3.5.2 LU8SSPBH-E..E..

Cannot be combined with manual override on LC8S/LD8S;

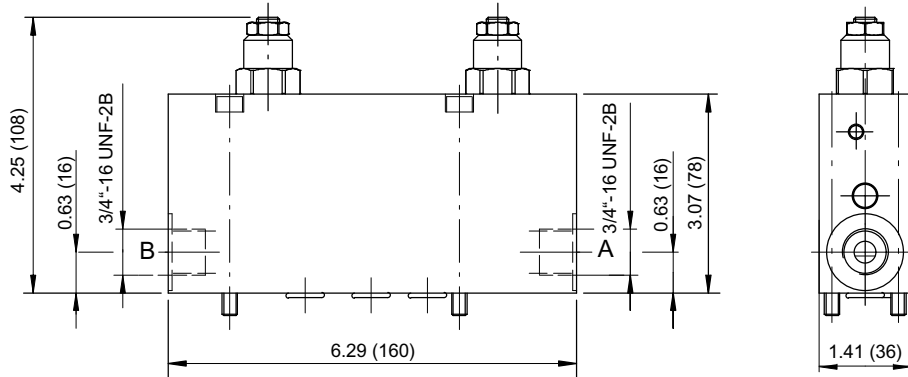

7 End sections

7.1 With no control function

7.1.1 Description

End sections with no control function are intended for the end of a valve block when no other control functions are needed. The LS signal is unloaded to tank.

The ports needed for the particular model are provided, as are tapped holes for securing the valve block.

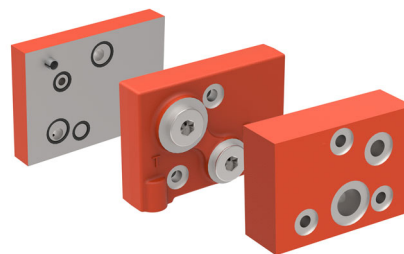

7.1.2 Overview of sections

Symbol	Description	Part number
	LU8SPUB-1 • end section without ports • LS to T	100040275
	LU8SPUT-1U78 • tank port T and pressure port P = 7/8"-14 UNF-2B • LS to T	100025078
	LU8SPWS-0U78 • pressure port P = 7/8"-14 UNF-2B • LS port = 9/16"-18 UNF-2B • LS carry-over (if unloading, remember the LS signal)	100029852

7.1.3 Dimensions [in (mm)]

7.1.3.1 LU8SPUB

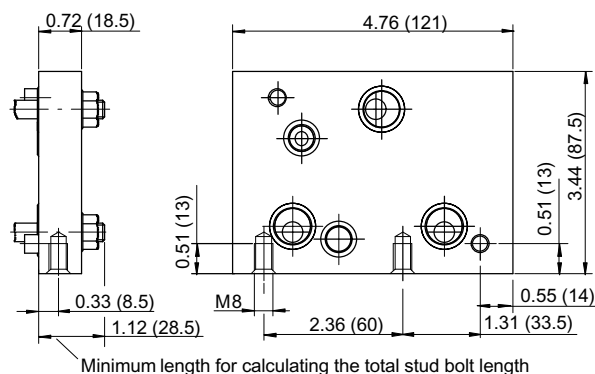

7.1.3.2 LU8SPUT

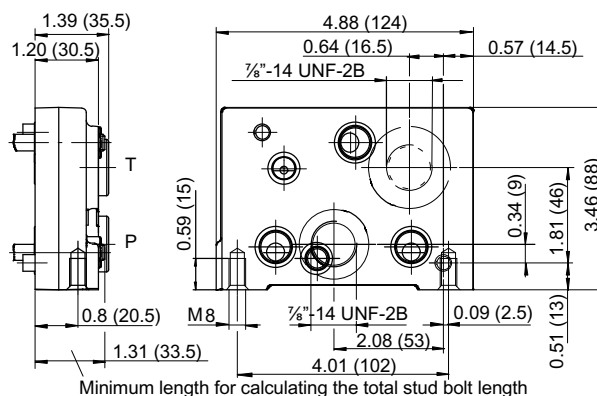

7.1.3.3 LU8SPWS

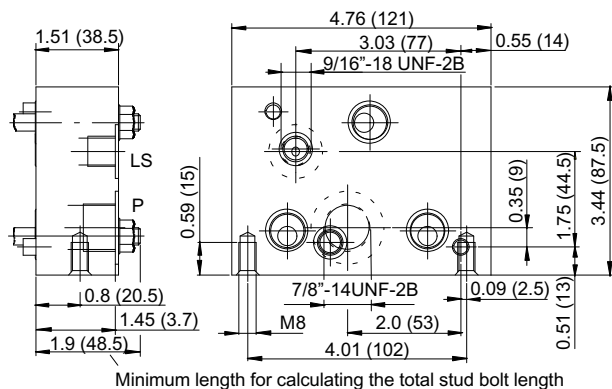

7.2 Safety valve for electro-hydraulic steering systems

7.2.1 Description

Block end section as safety valve for electro-hydraulic steering systems. When the electro-hydraulic steering is activated by energising the attached proportional valve (e.g. LC8S), the two 3/2 directional valves are also energised at the same time. As a result, the steering Orbitrol is disconnected. In automatic mode, if manual (i.e. emergency) steering corrections have to be made without first switching off automatic mode, a pressure develops in R or L, depending on the direction the Orbitrol is turned. This pressure passes through the shuttle valve to a pressure switch. The signal from the pressure switch cancels the automatic function and all solenoids are de-energised. Thus, the Orbitrol is directly connected to the steering cylinder and the normal manual steering function is active.

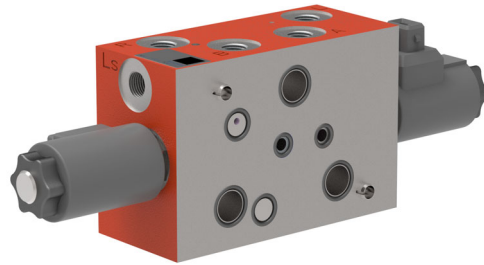

7.2.2 Technical data

General characteristics	Unit	Description, value
Inlet pressure	PSI (bar)	max. 3045 (210)
Flow rate	GPM (l/min)	6.60 (25)
Nominal voltage	V DC	12
Power consumption	Watt	27
Duty cycle	%	100
Connector socket		DIN 43650
Enclosure protection		AMP, GDM: IP65 DT: IP67 (DIN EN 60529)

7.2.3 Overview of sections

Symbol	Description	Part number
	LU8SPUL-0B14J24 <ul style="list-style-type: none"> • end section • connector socket: AMP Junior Timer • nominal voltage 24 V DC 	-

7.2.4 Connector socket

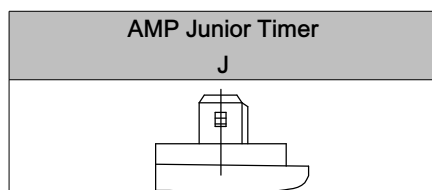

7.2.5 Dimensions

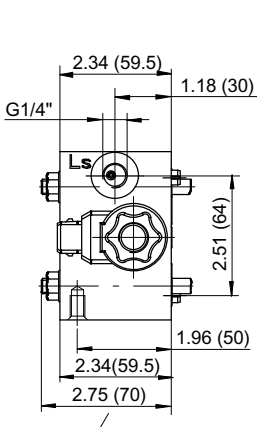

Minimum length for calculating the total stud bolt length

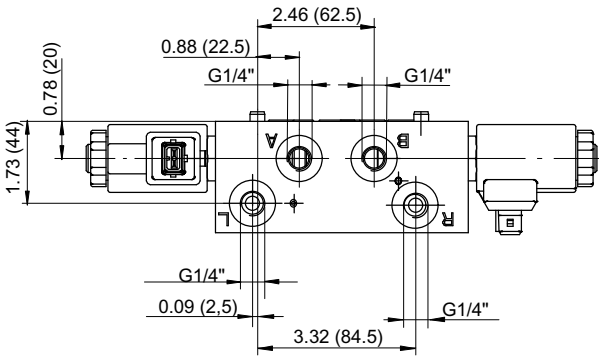
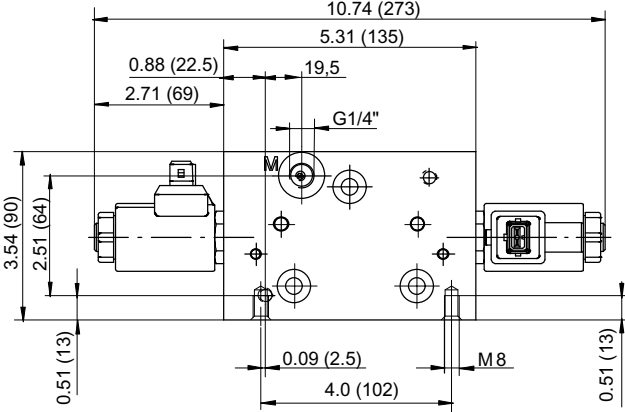

8 Configuration of control blocks

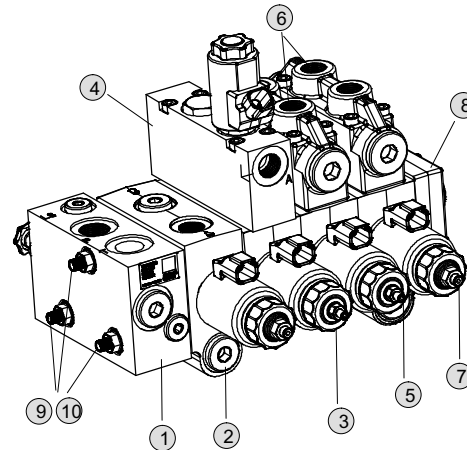
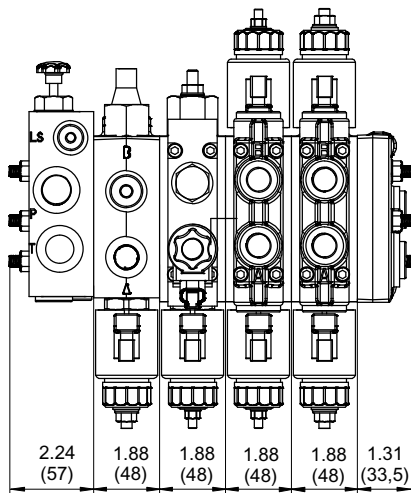

8.1 Ordering example

Pos	Criteria	Ordering code	Part number
1	Inlet section	LU8SSCK-0M22/12	100030622
2	Directional valve section	LC8SM3...	Defined by factory
3	Directional valve section	LD8SE3...	Defined by factory
4	Auxiliary valves that bolt-on to the top flange face O	LU8SPR1-DVADV-B-0M18T24	100024626
5	Directional valve section	LD8SE4...	Defined by factory
6	Auxiliary valves that bolt-on to the top flange face O	LU8SPRH.....	Defined by customer
7	Directional valve section	LC8SM4...	Defined by factory
8	End section	LU8SPUT-1M22	100038056
9	Stud bolt	M8x290	Defined by factory
10	Seal-Lock sealing nut	M8	100280470

8.2 Assembly kit

8.2.1 Description

To assemble the individual valve sections with assured functional reliability, 3 stud bolts and 3 or 6 (depends on inlet section) hex. nuts are necessary. Maximum tightening torque = 266 lbs (30 Nm). Tighten in 3 steps of 53 lbs (6 Nm), 142 lbs (16 Nm) and 266 lbs (30 Nm).

8.2.2 Calculating of the stud bolt length

Required stud bolt length of the inlet section (see dimension) + (1.88 in (48 mm) x no. of directional valve sections) + required stud bolt length of the end section (see dimension).

Example:

$2.24 \text{ in} + (1.88 \text{ in} \times 4) + 1.31 \text{ in} + 1.31 \text{ in} = 11.12 \text{ in}$
 $(57 \text{ mm} + (48 \text{ mm} \times 4) + 33.5 \text{ mm} + 33.5 \text{ mm}) = 282.5 \text{ mm}$

For ordering purposes, always round up to the calculated shaft screw length to the next 0.39 in (10 mm).

In our example, we therefore need to order 3 pcs. stud bolts á M8 x 11,41 (290 mm).

8.2.3 Ordering code

3 pcs. stud bolts M8 x (required length in mm)
 3 or 6 pcs. (depending on block configuration)
 Seal-Lock sealing nut M8, Part No: 100280470

8.2.4 Assembly of control block

In the example you see a control block with 9 sections. All sections are counted (inlet section, directional valve sections, end section and bolt-on sections).

Thus, for price calculation following control block must be selected from the price list: ZUB L.8S 9-Fach.

IMPORTANT: Maximum 10 directional sections in one valve block.

9 Liability

In the design and operation of hydraulic systems, all aspects of the potential failure modes and all planned operational conditions and uses of the equipment must be taken into consideration. Concerning risk assessment, please refer to the relevant Standards. The use of components that are not Original Bucher Replacement Parts and Accessories nullifies all warranty.

10 Note

This catalogue is intended for users with specialist knowledge. To ensure that all of the conditions necessary for the function and safety of the system are fulfilled, users must satisfy themselves as to the suitability of the units described here in. If there are any areas of doubt, please consult Bucher Hydraulics.

info.kl@bucherhydraulics.com

www.bucherhydraulics.com

© 2023 by Bucher Hydraulics GmbH, D-79771 Klettgau

All rights reserved.

Data is provided for the purpose of product description only, and must not be construed as warranted characteristics in the legal sense. The information does not relieve users from the duty of conducting their own evaluations and tests. Because the products are subject to continual improvement, we reserve the right to amend the product specifications contained in this catalogue.

Classification: 430.300. 410 100

100-P-000003-US-01/12.2023

L.8S Directional Valve

41/41